



GH-1440 ZX
GH-1640 ZX DRO
GH-1840 ZX DRO

METAL LATHE

50000721T
50000730T-50000740T
400/50/3

PARTS LIST



JPW Tool Group Hong Kong Limited

98 Granville Road, Tsimshatsui East, Kowloon, Hong Kong, PRC
www.jettools.com

Импортер в РФ: ООО «ИТА Технолджи»

105082, Москва, Переведеновский пер., д. 17
www.jettools.ru

Made in PRC / Сделано в КНР

Table of Contents

Table of Contents1

Stand Assembly 2-4

Brake Assembly 5-6

Bed Assembly 7-9

Headstock Assembly I 10-13

Headstock Assembly II 14-17

Headstock Assembly III 18-19

Headstock Assembly IV 20-21

Change Gear Box Assembly I 22-23

Change Gear Box Assembly II 24-25

Quick Change Gear Box I 26-28

Quick Change Gear Box II 29-30

Quick Change Gear Box III 31-32

Apron Assembly I 33-35

Apron Assembly II 36-38

Apron Assembly III 39-40

Carriage Assembly 41-43

Carriage Stop Assembly 44-45

Four Way Tool Post 46-47

Tailstock Assembly I 48-49

Tailstock Assembly II 50-51

Steady Rest Assembly 52-53

Follow Rest Assembly 54-55

Coolant And Work Light Assembly 56-57

Micro Carriage Stop Assembly 58

Protecting Guards For Three Rods 59

Safety Guard Cover 60

Parts List For Toolpost Protection Device 61

Parts List For Lead Screw Protection Device 62

Carriage Lubrication 63

Other Parts 64

Electrical Components 65

Electric Cabinet 66

Wiring Diagram 67

Flexible Stainless Wire Woven Tube 68

Stand Assembly

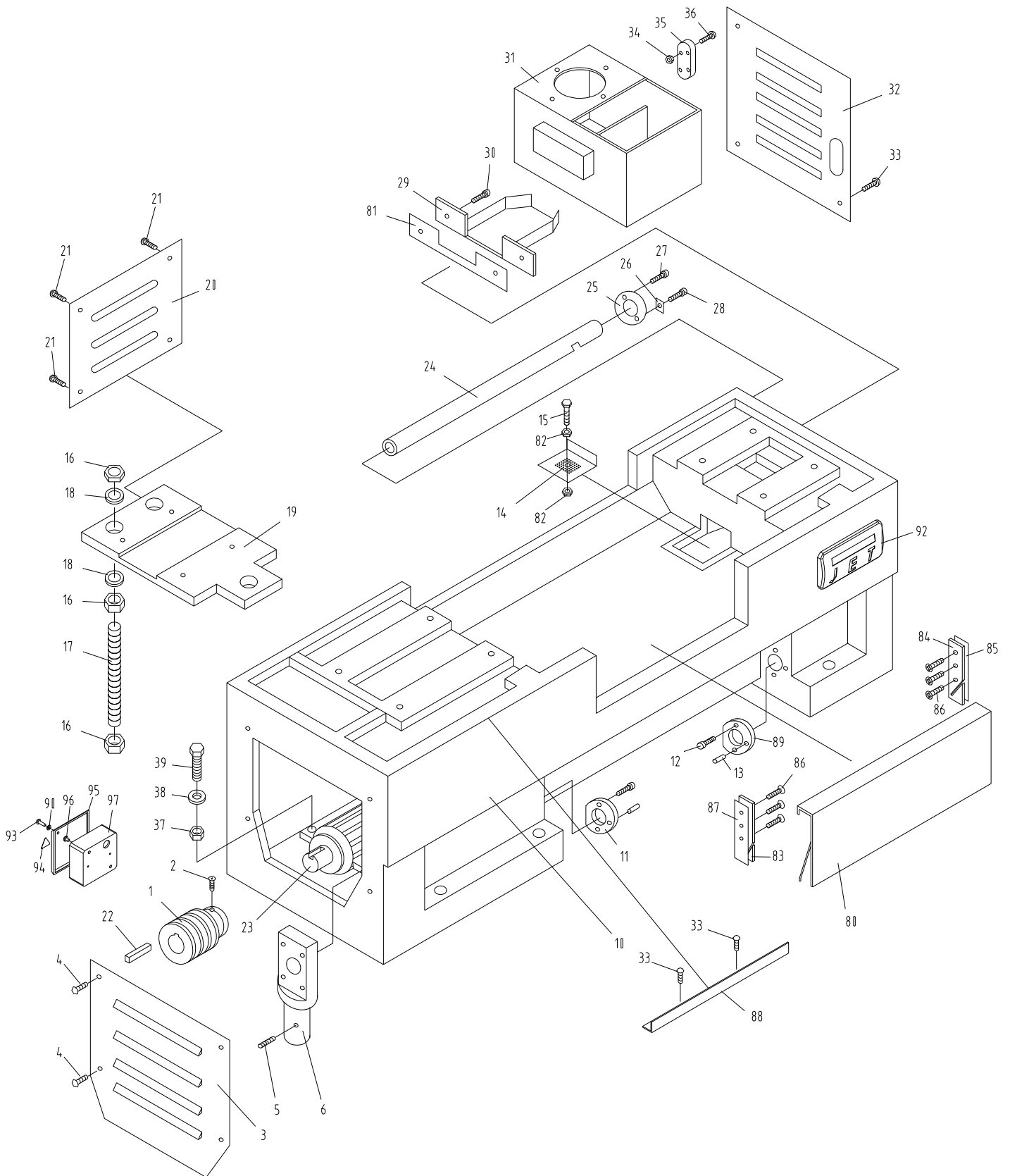

Stand Assembly

Index No.	Part No.	Description	Size	Qty.
1	ZX01101AE	Pulley		1
2	ZXS2	Cylindrical End Set Screw	M8x16	1
3	ZX01734-G	Cover		1
4	ZXS4	Cross Head Screw	M6x14	4
5	ZXS2	Cylindrical End Set Screw	M8x16	1
6	ZX01701	Pedal Rod Support		1
10	ZX01102AN-G	New Bed Stand (for 40" models)		1
	ZX01102BN-G	New Bed Stand (for 60" models)		1
	ZX01102CN-G	New Bed Stand (for 80" models)		1
11	ZX01703	Fixed Support		1
12	TS1514021	Socket Head Cap Screw	M6x14	4
13	ZXS13	Taper Pin	5x20	2
14	ZX01705	Water Leaking Chip Guard		1
15	ZXS15A	Cross Head Screw	M5x20	4
16	TS1540121	Hex Nut	M20	9
17	ZX01702	Bolt		3
18	TS1550111	Flat Washer	A20	6
19	ZX01122B	Motor Mounting Plate		1
20	ZX01726-G	Cover		1
21	ZXS4	Cross Head Screw	M6x14	4
22	ZXS22	Key	10x8x70	1
23	ZX-S23AE	Main Motor (for 14" models)	5.5kW, 4P, 3Ph	1
	ZXS23B	Main Motor (for 16"/18" models)	5.5kW, 6P, 3Ph	1
23a	GH1440ZXK1085	Main Motor Label (not shown)		1
	GH16/GH18ZXK991	Main Motor Label (not shown)		1
24	ZX017609A	Wire Conduit (for 1640/1840ZX)		1
	ZX017609B	Wire Conduit (for 1660/1860ZX)		1
	ZX017609C	Wire Conduit (for 1880ZX)		1
26	ZX01706	Locking Plate		1
28	ZXS15	Cross Head Screw	M4x6	1
29	ZX01711-G	Water Reception Plate		1
30	ZXS4	Cross Head Screw	M6x14	2
31	ZX01510	Coolant Tank		1
32	ZX01714-G	Cover		1
33	ZXS4	Cross Head Screw	M6x14	6
34	ZXS34	Nut	M3	4
35	ZXS35	Coolant Indicator		1
36	ZXS36	Cross Head Screw	M3x20	4
37	TS1540072	Hex Nut	M10	4
38	TS1550071	Flat Washer	M10	4
39	TS1491041	Hex Cap Bolt	M10x30	4
80	ZX01716A-G	Stand Front Cover (for 1440/1640/1840ZX)		1
	ZX01716B-G	Stand Front Cover (for 1660/1860ZX)		1

Stand Assembly

Index No.	Part No.	Description	Size	Qty.
	ZX01716C-G	Stand Front Cover (for 1880ZX)		1
81	ZX01501	Gasket		1
82	ZXS82	Hex Nut	M5	2
83	ZX01740	Left Tray		1
84	ZX01741	Right Tray		1
85	ZX01511	Gasket		2
86	ZXS86	Cross Head Screw	M5x16	6
87	ZX01512	Gasket		1
	JX21004	Terminal Board (not shown)		1
	18301	Junction Box (not shown)		1
	D974	Plastic Fitting (not shown)		1
88	ZX05753-G	Extending Plate		1
89	ZX01703A	Fixed Support (serial # 7090341 and higher)		1
90	ZXS91	Flat Washer	.6	2
92	JET-165	JET LOGO (serial #16081085 and higher)		1
93	GB2672-M6x20	Screw	M6x20	2
94	C613618302	Warning Label		1
95	GH1440A18304-G	Wiring Box Cover		1
96	GB818-M6x8	Cross Head Screw	M6x8	2
97	GH1640ZX18303A-G	Wiring Box Cover		1

Brake Assembly

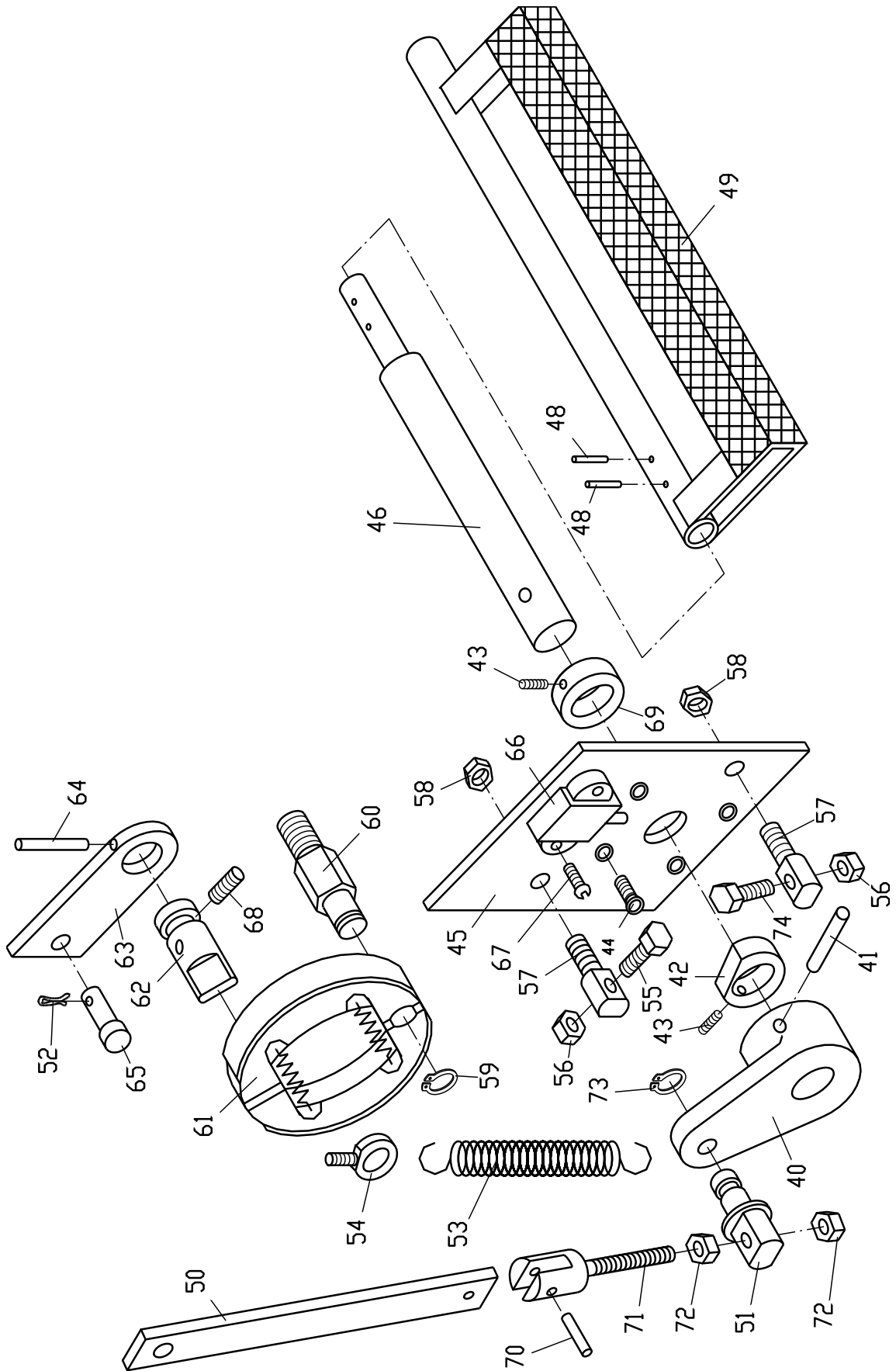

Brake Assembly

Index	Part			
No.	No.	Description	Size	Qty.
40	ZX22101-G	Fork		1
41	ZXS41	Spring Pin	.5x40	1
42	ZX22703	Butt Nail Support		1
43	TS1524021	Set Screw	M8x10	1
44	ZXS44	Cross Head Screw	M5x20	4
45	ZX22714	Positioning Plate		1
46	ZX22704A	Driving Shaft-Longer		1
48	ZXS48	Spring Pin	.5x30	2
49	ZX22712A	Pedal (for 1440/1640/1840ZX, serial # 7080340 and lower)		1
	ZX22712AE-G	Pedal (for 1440/1640/1840ZX, serial # 7090341 and higher)		1
	ZX22712B	Pedal (for 1660/1860ZX, serial # 7080340 and lower)		1
	ZX22712BE-G	Pedal (for 1660/1860ZX, serial # 7090341 and higher)		1
	ZX22712C	Pedal (for 1880/2280ZX, serial # 7080340 and lower)		1
	ZX22712CE-G	Pedal (for 1880/2280ZX, serial # 7090341 and higher)		1
50	ZX-22710A-G	Draw Bar (for 14" models)		1
	ZX22710B-G	Draw Bar (for 16" models)		1
	ZX22710C-G	Draw Bar (for 18" models)		1
51	ZX22706	Connecting Shaft		1
52	ZXS52	Split Pin	.2x20	2
53	ZXS53	Tensile Spring	3.5x26x190	1
54	ZXS54	Eyebolt	M8	1
55	TS1490091	Hex Cap Bolt	M8x50	1
56	TS1540061	Hex Nut	M8	1
57	ZX22707A	Butt Rod Support		1
58	TS1540072	Hex Nut	M10	1
59	ZXS59	C-Clip	.8	1
60	ZX22701	Positioning Shaft		1
61	ZXS61	Brake Shoe		1
62	ZX22702	Brake Shaft		1
63	ZX22708	Connecting Plate		1
64	ZXS64	Elastic Pin	.5x25	1
65	ZX22709	Connecting Shaft		1
66	ZXS66	Stroke Switch		1
67	ZXS67	Screw	M4x25	2
68	ZXS68	Cylindrical End Set Screw	M5x10	1
69	ZX22711	Butt Nail Support		1
70	ZXS70	Pin	.5n6x20	1
71	ZX22715	Adjust Bolt		1
72	TS1540061	Hex Nut	M8	1
73	ZXS73	C-Clip	12	2
74	ZXS74	Hex Cap Bolt	M8x35	1

Bed Assembly

Index No.	Part No.	Description	Size	Qty.
1	ZX01104A-G	Bed (for 1440/1640/1840ZX)		1
	ZX01104B-G	Bed (for 1660/1860ZX)		1
	ZX01104C-G	Bed (for 1880ZX)		1
2	TS1550101	Flat Washer	B16	8
3	ZXB3	Hex Cap Bolt	M16x50	8
4	ZX01704A	Rack		1
5	TS1516041	Hex Socket Cap Screw (for 1440/1640/1840ZX)	M10x35	10
		Hex Socket Cap Screw (for 1660/1860ZX)	M10x35	14
		Hex Socket Cap Screw (for 1880ZX)	M10x35	18
6	ZXB6	Taper Pin (for 1440/1640/1840ZX)	8x50	10
		Taper Pin (for 1660/1860ZX)	8x50	14
		Taper Pin (for 1880ZX)	8x50	18
7	ZX01706A	Rack (for 1440/1640/1840ZX)		4
		Rack (for 1660/1860ZX)		6
		Rack (for 1880ZX)		8
8	ZX01112-G	Saddle		1
9	TS1551081	Lock Washer	12	4
10	TS1517041	Hex Socket Cap Screw	M12x55	4
12	ZXB12	Thread Taper Pin	12x70	2
13	TS1491101	Hex Cap Bolt	M10x55	2
14	TS1550071	Flat Washer	M10	2
15	TS1503021	Hex Socket Cap Screw	M8x12	5
16	TS1550041	Flat Washer	8	5
17	ZX-01741A-G	Splash Guard (for 1440ZX)		1
	ZX01741C-G	Splash Guard (for 1640ZX)		1
	ZX01741D-G	Splash Guard (for 1660ZX)		1
	ZX01741E-G	Splash Guard (for 1840ZX)		1
	ZX01741F-G	Splash Guard (for 1860ZX)		1
	ZX01741G-G	Splash Guard (for 1880ZX)		1
18	ZXB18	Shear Pin	5x35	2
19	ZX01708ANE	New Lead Screw (for 40" models)		1
	ZX01708BNE	New Lead Screw (for 60" models)		1
	ZX01708CNE	New Lead Screw (for 80" models)		1
20	ZXB20	Flat End Set Screw	M6x10	2
21	ZX01109N	New Sleeve		1
22	ZX1204	Double Row Spherical Ball Bearing	20x47x14	2
23	ZXB23	C-Clip	20	2
24	ZX01110N-G	New Bracket		1
25	ZX01111-G	Cover		1
26	TS1514021	Hex Socket Cap Screw	M6x14	4
27	ZXB27	Taper Pin	6x60	1
28	TS1516061	Hex Socket Cap Screw	M10x50	1
29	ZXB29	Oil Cup	10	2
30	TS223991	Hex Socket Cap Screw	M10x100	1
31	ZXB31	Taper Pin	6x100	1
32	ZX01108N	New Sleeve		1
33	ZX01709AN	New Feed Rod (for 40" models)		1

Bed Assembly

Index	Part			
No.	No.	Description	Size	Qty.
	ZX01709BN	New Feed Rod (for 60" models)		1
	ZX01709CN	New Feed Rod (for 80" models)		1
36	ZX01707A	Control Rod (for 1440/1640/1840ZX)		1
	ZX01707B	Control Rod (for 1660/1860ZX)		1
	ZX01707C	Control Rod (for 1880ZX)		1
38	ZX06720	Small Shaft		1
39	ZX06001C-3	Sleeve		1
40	ZX06001C-2	Spacer		1
41	ZXB41	Spring	1x75x25	3
42	ZX06001C-1-G	Bracket		1
43	TS1515011	Hex Socket Cap Screw	M8x16	2
44	ZXB44	Lever		1
45	ZX06001C-4	Long Lever Sleeve		1
46	ZXB46	Hex Nut	M8	2
47	ZXB47	Set Screw	M8x28	2
48	ZX06001C-5	Direction Change Ring		1
49	ZXB49	Pin	.8n6x20	1
50	ZXB50	Taper Pin	.3x20	1
51	TS1516061	Hex Socket Cap Screw	M10x48	2
52	ZX05741	Threaded Tube		2
53	TS1540081	Hex Nut	M12	2
59	ZX01715C-G	Cover		1
60	ZXB60	Cross Recessed Pan Head Screw	M6x18	4
66	1440R01305	Plate (serial #16081100 and lower)		1
	GHB1340A01301-2	Plate (serial #16081101 and higher)		1
67	GB827-3x6	Rivet	3x6	4
90	C0632A01301E-G	Switch Box		1
91	ZXB91E	Hex Socket Cap Screw	M8x20	2
92	ZXB92E	Screw	M6x16	1
93	CO632A01705E	Bushing		1
94	ZXB94E	Steel Ball	.6	1
95	ZXB95E	Spring		1
96	ZXB96E	Screw	M8x16	1
97	CO632A01504E-G	Switch Box Cover		1
98	ZXB98E	Hex Socket Cap Screw	M5x10	4
99	CO632A01503E	Plug		2
100	ZX01706E	Positioning Sleeve		1
101	ZXB101E	Screw	M5x8	1
102	ZXLRG14	Rubber Mat (for 14" models)		1
	ZXLRG16	Rubber Mat (for 16" models)		1
	ZXLRG18	Rubber Mat (for 18" models)		1
103	ZXRRG	Rubber Mat		1
104	SQ2, SQ3	Stroke Switch	LXW5-11D1	2
105	GB97.2	Flat Washer	.5	5
106	GB2672	Hex Socket Asterisk Pan Head Screw	M5x8	5
107	ZX-18717-G	Line Groove		1
108	C613618302	Warning Label		1

Headstock Assembly I

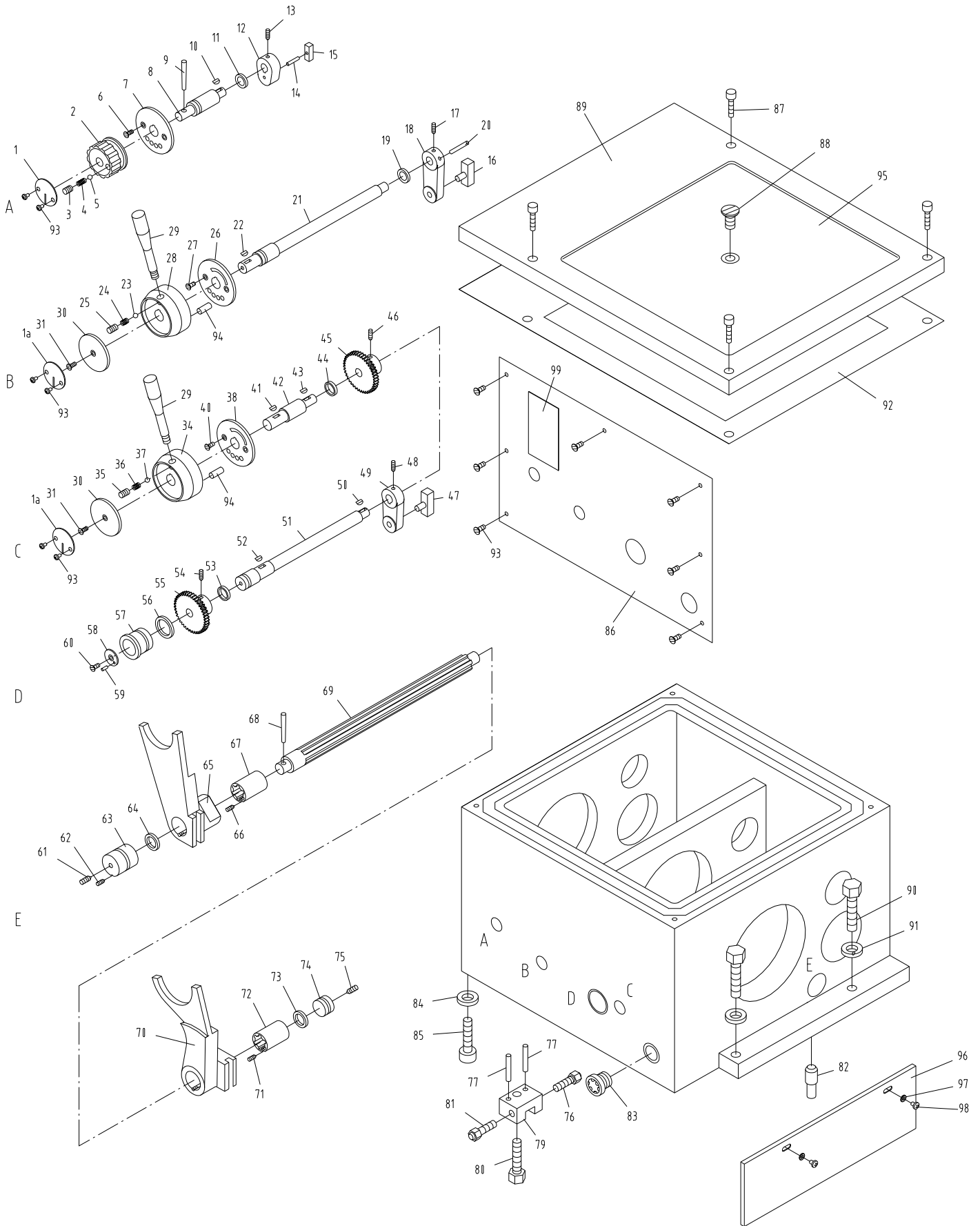

Headstock Assembly I

Index No.	Part No.	Description	Size	Qty.
1	ZX02306	Round Sign Plate (serial #16081100 and lower)		1
	C6136ZK-02304-1	Round Sign Plate (serial #16081101 and higher)		1
1a	ZX02306	Round Sign Plate (serial #16081100 and lower)		2
	14~18R02303-2	Round Sign Plate (serial #16081101 and higher)		2
2	ZX02122-G	Positioning Handle		1
3	ZXH3	Flat End Set Screw	M10x12	1
4	ZXH4	Spring	YI-1x8x25	1
5	ZXH5	Steel Ball	.8	1
6	ZXH6	Countersunk Head Screw	M5x12	2
7	ZX02743-G	Positioning Disc		1
8	ZX02738	Shaft		1
9	ZXH9	Taper Pin	.5x55	1
10	ZXH10	Woodruff Key	.4x16	1
11	ZXH11	Ring Seal	.25x2.4	1
12	ZX02116	Crank		1
13	TS1523051	Set Screw	M6x16	1
14	ZXH14	Pin	.5n6x28	1
15	ZX02302	Poking Block		1
16	ZX02738C	Pin Block		1
17	TS1523051	Set Screw	M6x16	1
18	ZX02114	Crank		1
19	ZXH11	Ring Seal	.25x2.4	1
20	ZXH20	Pin	.5x30	1
21	ZX02734	Shaft		1
22	ZXH10	Woodruff Key	.4x16	1
23	ZXH5	Steel Ball	.8	1
24	ZXH4	Spring	YI-1x8x25	1
25	ZXH3	Flat End Set Screw	M10x12	1
26	ZX02733-G	Left Positioning Disc		1
27	ZXH6	Countersunk Head Screw	M5x12	2
28	ZX02113-G	Left Lever Support		1
29	ZX02741-G	Handle		2
30	ZX02732	Cover		2
31	ZXH6	Countersunk Head Screw	M5x12	2
34	ZX02119-G	Right Lever Support		1
35	ZXH3	Flat End Set Screw	M10x12	1
36	ZXH4	Spring	YI-1x8x25	1
37	ZXH5	Steel Ball	.8	1
38	ZX02728-G	Right Positioning Disc		1
40	ZXH6	Countersunk Head Screw	M5x12	2
41	ZXH10	Woodruff Key	.4x16	1
42	ZX02727	Shaft		1
43	ZXH10	Woodruff Key	.4x16	1
44	ZXH11	Ring Seal	.25x2.4	1
45	ZX02730	Gear	1.5m36T	1
46	TS1523051	Set Screw	M6x16	1
47	ZX02738C	Pin Block		1

Headstock Assembly I

Index	Part			
No.	No.	Description	Size	Qty.
48	TS1523051	Set Screw	M6x16	1
49	ZX02111	Crank		1
50	ZXH10	Woodruff Key	4x16	1
51	ZX02731/1	Control Shaft		1
52	ZXH10	Woodruff Key	4x16	1
53	ZXH11	Ring Seal	25x2.4	1
54	ZXH54	Taper End Set Screw	M6x16	1
55	ZX02732/2	Gear	1.5m36T	1
56	ZXH56	Ring Seal	40x3.1	1
57	ZX02110	Bushing		1
58	ZX02729	Cover		1
59	ZXH59	Pin	3n6x10	1
60	ZXH6	Countersunk Head Screw	M5x12	1
61	ZXH61	Countersunk Head Screw	M8x12	1
62	ZXH62	Flat End Set Screw	M8x12	1
63	ZX02115C	Bearing Support		1
64	ZXH64	Ring Seal	40x3.1	1
65	ZX02115	Left Fork		1
66	ZXH66	Flat End Set Screw	M6x10	1
67	ZX02120A/2	Bushing		1
68	ZXH68	Taper Pin	6x35	1
69	ZX02736	Control Shaft		1
70	ZX02112	Right Fork		1
71	ZXH66	Flat End Set Screw	M6x10	1
72	ZX02120A/2	Bushing		1
73	ZXH73	Ring Seal	30x3.1	1
74	ZX02735	Blocking Piece		1
75	ZXH61	Countersunk Head Screw	M8x12	1
76	ZX02744	Adjusting Screw		1
77	ZXH77	Taper Pin	8x40	2
79	ZX92124	Adjusting Block		1
80	ZXH80	Hex Cap Bolt	M12x50	1
81	ZX02744	Adjusting Screw		1
82	ZX02736C	Positioning Pin		1
83	ZXH83	Oil Sight Glass		1
84	ZXH84	Flat Washer	A16	2
85	ZXH85	Hex Socket Cap Screw	M16x50	2
86	GH1440ZX02301-301	Label (for 1440ZX) (serial #16081101 and higher)		1
	ZX02301C	Label (for 1640ZX) (serial #16081100 and lower)		1
	ZX02301D	Label (for 1660ZX) (serial #16081100 and lower)		1
	GH1640ZX02301-302	Label (for 1640/1660ZX) (serial #16081101 and higher)		1
	ZX02301E	Label (for 1840ZX) (serial #16081100 and lower)		1
	ZX02301F	Label (for 1860ZX) (serial #16081100 and lower)		1
	ZX02301G	Label (for 1880ZX) (serial #16081100 and lower)		1
	GH1860ZX02301-303	Label (for 1840/1860/1880ZX) (serial #16081101 and higher)		1
87	TS1504071	Hex Socket Cap Screw	M8x35	4
88	ZXH88	Countersunk Head Screw	M16x25	1

Headstock Assembly I

Index No.	Part No.	Description	Size	Qty.
89	ZX02117-G	Top Cover		1
90	ZXH90	Hex Cap Bolt		2
91	ZXH91	Flat Washer	A16	2
92	ZX02505	Paper Gasket		1
93	ZXH93	Cross Recessed Pan Head Screw (serial #16081100 and lower)		
			M3x6	13
	GB2672-M3x6	Screw (serial #16081101 and higher)	M3x6	13
94	ZXH94N	Pin	4n6x15	2
95	ZXH95	Rubber Mat		1
96	ZX02740-G	Front Cover		1
97	GB97.2-6	Flat Washer	6	2
98	GB818-M6x8	Cross Head Screw	M6x8	2
99	GHB1340A11304-12	Warning Sign Label (serial #16081101 and higher)		1

Headstock Assembly II

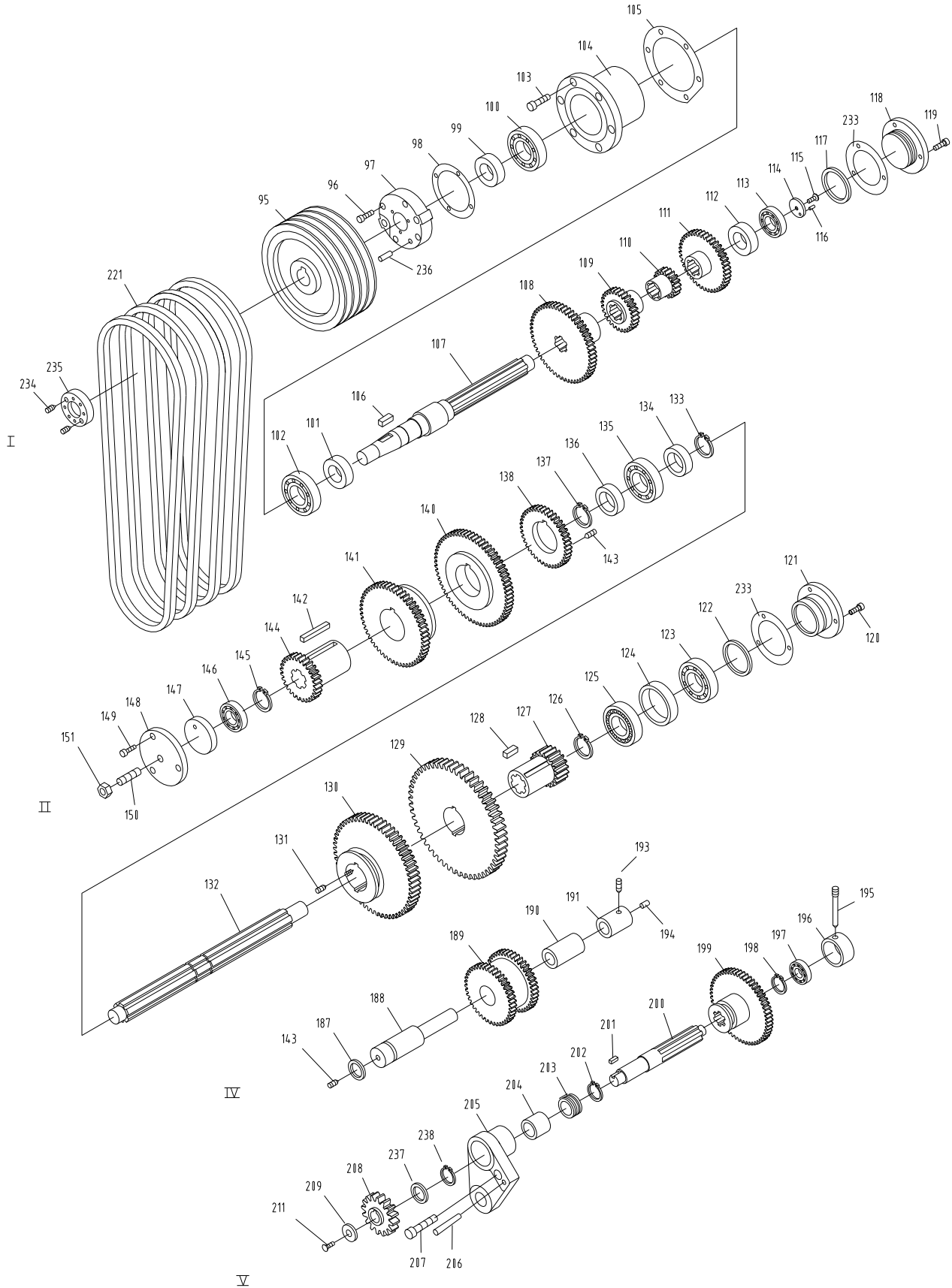

Headstock Assembly II

Index	Part			
No.	No.	Description	Size	Qty.
95	ZX02107	Pulley		1
96	TS1514041	Hex Socket Cap Screw	M6x25	4
97	ZX02106	Bearing Cover		1
98	ZX02506	Gasket		1
99	ZXH99	Ring Seal	32x52	1
100	BB6207	Ball Bearing	35x72x17	1
101	ZXH102	Sleeve	30x10	1
102	BB6207	Ball Bearing	35x72x17	1
103	TS1515031	Hex Socket Cap Screw	M8x25	6
104	ZX02105	Bearing Support		1
105	ZX02502	Gasket		1
106	ZXH106	Flat Key	10x8x35	1
107	ZX02709	Shaft		1
108	ZX-02754X	Gear (for 14" models)	2.5m52T	1
	ZX02754X/6P	Gear (for 16"/18" models)	2.5m61T	1
109	ZX-02753X	Gear (for 14" models)	2.5m28T	1
	ZX02753X/6P	Gear (for 16"/18" models)	2.5m32T	1
110	ZX02752X	Gear	2.5m18T	1
111	ZX-02751X	Gear (for 14" models)	2.5m41T	1
	ZX02751X/6P	Gear (for 16"/18" models)	2.5m47T	1
112	ZXH112	Sleeve		1
113	BB6305/P6	Ball Bearing	25x62x17	1
114	ZXH114	Shaft End Lock Ring	32	1
115	ZXH115	Countersunk Head Screw	M6x20	1
116	ZXH59	Pin	3n6x10	1
117	ZXH117	Ring Seal	60x3.1	1
118	ZX02104-G	Blocking Flange		1
119	TS1514021	Hex Socket Cap Screw	M6x15	3
120	TS1514021	Hex Socket Cap Screw	M6x15	3
121	ZX19101-G	Blocking Flange		1
122	ZXH117	Ring Seal	60x3.1	1
123	BB6305	Ball Bearing	25x62x17	1
124	ZXH124	Sleeve	62x6	1
125	BB6305	Ball Bearing	25x62x17	1
126	ZXH126	Circle Clip For Shaft	35	1
127	ZX02705	Gear	3m19T	1
128	ZXH128	Flat Key	8x7x50	2
129	ZX02706	Gear	3m67T	1
130	ZX02707	Gear	3m59T	1
131	ZXH62	Flat End Set Screw	M8x12	1
132	ZX02708	Shaft		1
133	ZXH133	C-Clip	35	1
134	ZXH134	Sleeve	35x8	1
135	BB6007	Ball Bearing	35x62x14	1
136	ZXH136	Sleeve	35x8	1
137	ZXH133	C-Clip	35	1
138	ZX-02756	Gear (for 14" models)	2.5m42T	1

Headstock Assembly II

Index No.	Part No.	Description	Size	Qty.
	ZX02756/6P	Gear (for 16"/18" models)	2.5m36T	1
140	ZX-02757	Gear (for 14" models)	2.5m65T	1
	ZX02757/6P	Gear (for 16"/18" models)	2.5m65T	1
141	ZX-02758	Gear (for 14" models)	2.5m55T	1
	ZX02758/6P	Gear (for 16"/18" models)	2.5m51T	1
142	ZXH142	Flat Key	10x6x60	2
143	ZXH143	Flat Head Set Screw	M8x12	2
144	ZX-02755X	Gear (for 14" models)	2.5m31T	1
	ZX02755X/6P	Gear (for 16"/18" models)	2.5m22T	1
145	ZXH133	C-Clip	35	1
146	BB6305	Ball Bearing	25x62x17	1
147	ZXH147	Pushing Disc	62	1
148	ZX02109C	Cover		1
149	TS1514021	Hex Socket Cap Screw	M6x15	3
150	ZXH150	Set Screw	M12x65	1
151	ZXH151	Hex Nut	M12	1
187	ZXH187	Ring Seal	35x3.1	1
188	ZX02714	Shaft		1
189	ZX02716	Double Gear	2m48T	1
190	ZX02303	Copper Sleeve		1
191	ZX02734C	Positioning Sleeve		1
193	TS1524041	Set Screw	M8x15	1
194	ZX02733C	Blocking Piece		1
195	ZX02718	Taper End Set Screw		1
196	ZX02114C	Sleeve		1
197	BB6203	Ball Bearing	17x40x12	1
198	ZXH198	C-Clip	28	1
199	ZX02717	Gear	2m65T	1
200	ZX02715	Shaft		1
201	ZXH201	Flat Key	5x5x1	1
202	ZXH198	C-Clip	28	1
203	ZX02722C	Sleeve		1
204	ZX02301	Oil Bushing (serial # 10100726 and lower)		1
	CDL50002302	Oil Bushing (serial # 10120727 and higher)		1
205	ZX08106A-G	Bracket (for Shaft V, Vb) (for 14" /16" models)		1
	ZX08106B-G	Bracket (for Shaft V, Vb) (for 18" models)		1
206	ZXH77	Taper Pin	8x40	1
207	TS1516021	Hex Socket Cap Screw	M10x25	1
208	TNMP08706A (T)	Gear (for 14"/16" models)	3.5m15T	1
	TNMP08706B (T)	Gear (for 18" models)	4m15T	1
209	ZX02724C	Flat Washer		1
210	ZXH59	Pin	3n6x10	1
211	ZXH211	Countersunk Head Screw	M5x16	1
221	VBA1930	V-Belt (for 14" models)	A-1930	4
	VBA1956	V-Belt (for 16" models)	A-1956	4
	VBA1981	V-Belt (for 18" models)	A-1981	4
233	ZX02506	Paper Gasket		2

Index	Part			
No.	No.	Description	Size	Qty.
234	ZXH234	Set Screw	M8x6	2
235	ZX02743N	Clamping Round Nut		1
236	ZXH236	Pin	.8x30	2
237	ZXH237	Seal Ring (serial # 10120727 and higher)	25x40x70	1
238	ZXH238	Steel C-clip (serial # 10120727 and higher)	.32	1

Headstock Assembly III

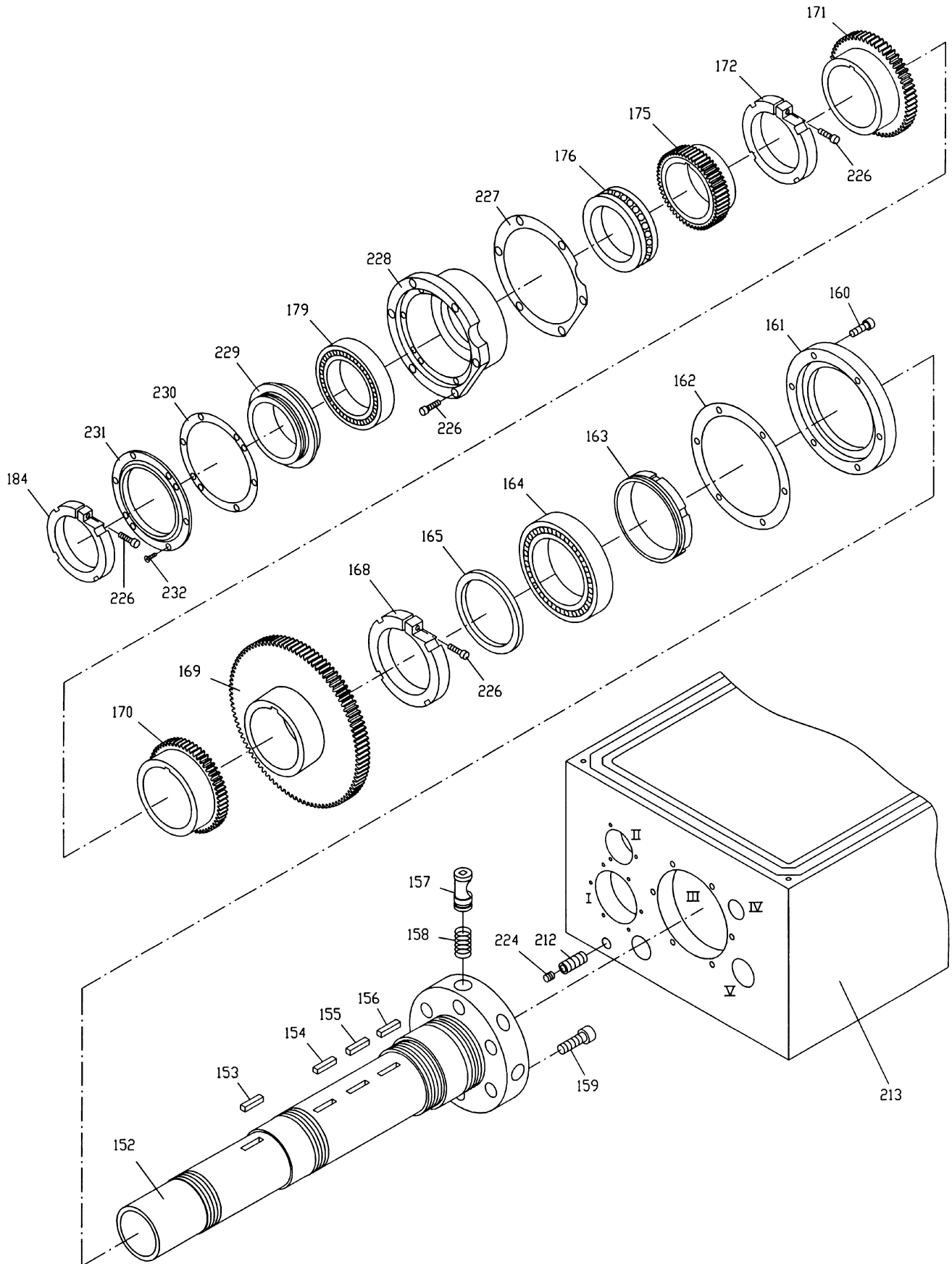

Headstock Assembly III

Index No.	Part No.	Description	Size	Qty.
152	ZX02704	Spindle		1
153	ZXH153	Flat Key	10x8x40	1
154	ZXH154	Flat Key	10x8x50	1
155	ZXH155	Flat Key	12x8x50	1
156	ZXH156	Flat Key	14x9x50	1
157	ZX02701	Cam Lock		6
158	ZXH158	Spring	1x8x25	6
159	ZX02703	Cam Positioning Screw		6
160	TS1516031	Hex Socket Cap Screw	M10x28	6
161	ZX02102-G	Bearing Front Cover		1
162	ZX02501	Gasket		1
163	ZX02702	Oil Splashing Ring		1
164	NN3024/P5	Taper Roller Bearing	120x180x46	1
165	ZX02726	Lining		1
168	ZX02725A	Round Nut w/Screw		1
169	ZX02723	Gear	.3m98T	1
170	ZX02722	Gear	.3m50T	1
171	ZX02721	Gear	.3m58T	1
172	ZX02720A	Round Nut w/Screw		1
175	ZX02710	Gear	.2m65T	1
176	51120/P5	Thrust Bearing	100x135x25	1
179	BB7020AC/P5	Angular Bearing	100x150x24	1
184	ZX02713A	Round Nut w/Screw		1
212	ZXH212A	Drain plug		1
213	ZX02101AN-G	Headstock Casting (14" models)		1
	ZX02101BN-G	Headstock Casting (16" models)		1
	ZX02101CN-G	Headstock Casting (18" models)		1
224	ZXG38-3A	Screw		1
226	ZXH226	Hex Socket Cap Screw	M8x28	9
227	ZX02502F	Gasket (The part is canceled from serial # 13060962)		1
228	ZX02108F	Bearing Support		1
229	ZX02711F	Sleeve		1
230	ZX02510F	Gasket		1
231	ZX02761F	Bearing Back Cover		1
232	ZXH232	Screw	M5x10	6

Headstock Assembly IV

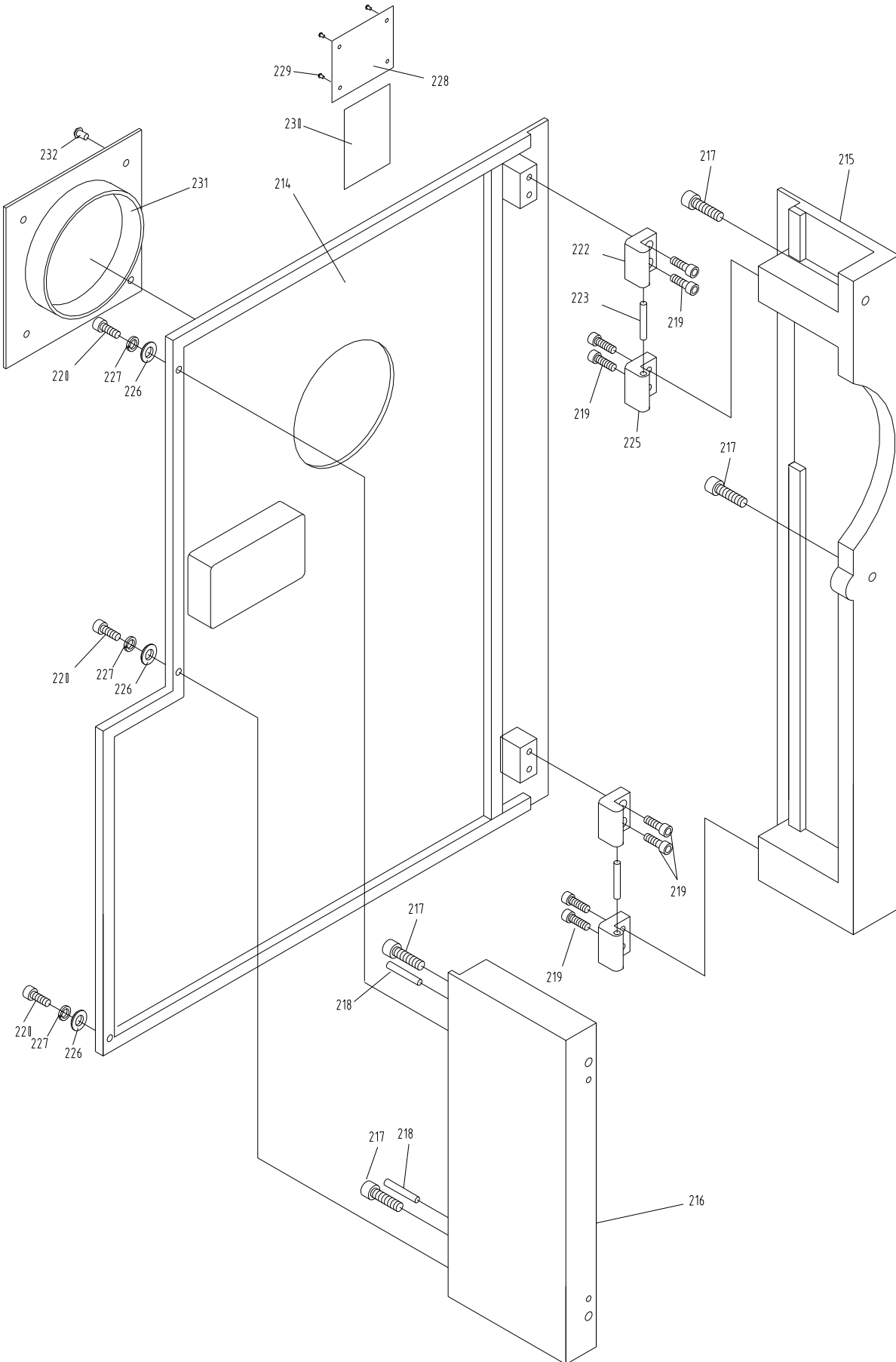

Headstock Assembly IV

Index No.	Part No.	Description	Size	Qty.
214	ZX08302A-G	Back Cover (for 14" models)		1
	ZX08302B-G	Back Cover (for 16" models) (serial #18101183 and lower)		1
	ZX08302C-G	Back Cover (for 18" models) (serial #18101183 and lower)		1
	ZX08719A-G	Back Cover (for 14" models) (serial #20101280 and high)		1
	ZX08719B-G	Back Cover (for 16" models) (serial #20101280 and high)		1
	ZX08719C-G	Back Cover (for 18" models) (serial #20101280 and high)		1
215	ZX-08114A-G	Rear Side Plate (for 14" models)		1
	ZX08114B-G	Rear Side plate (for 16" models)		1
	ZX08114C-G	Rear Side plate (for 18" models)		1
216	ZX08113A-G	Front Side plate (for 14" models)		1
	ZX08113B-G	Front Side plate (for 16" models)		1
	ZX08113C-G	Front Side plate (for 18" models)		1
217	TS1515031	Hex Socket Cap Screw	M8x25	4
218	ZXH218	Taper Pin	.6x25	2
219	TS1514031	Hex Socket Cap Screw	M6x20	8
220	TS1514021	Hex Socket Cap Screw	M6x15	3
222	ZX08712	Upper Hinge		2
223	ZXH223	Pin	.6n6x40	2
225	ZX08711	Lower Hinge		2
226	ZXH226	Flat Washer (serial # 10040691 and higher)	.6	3
227	ZXH227	Spring Washer (serial # 10040691 and higher)	.6	3
228	GH1440ZXK1084	Gear Box Sign Label (For GH1440ZX only)		1
	GH1640ZXK983	Gear Box Sign Label (For GH1640ZX only)		1
	GH1840ZXK984	Gear Box Sign Label (For GH1840ZX only)		1
	GH1860ZXK985	Gear Box Sign Label (For GH1860ZX only)		1
	GH1880ZXK986	Gear Box Sign Label (For GH1880ZX only)		1
229	ZXH93	Cross Recessed Pan Head Screw (serial #16081102 and lower)		
			M3x6	4
	GB2672-M3x6	Screw (serial #17121161 and higher)	M3x6	4
230	GHB-1340A11304-12	Label Screw (serial #18041171 and higher)		1
231	C6250A-08704	Cover (serial #20101280 and high)		1
232	GB818	Screw (serial #20101280 and high)	M6x10	4

Change Gear Box Assembly I

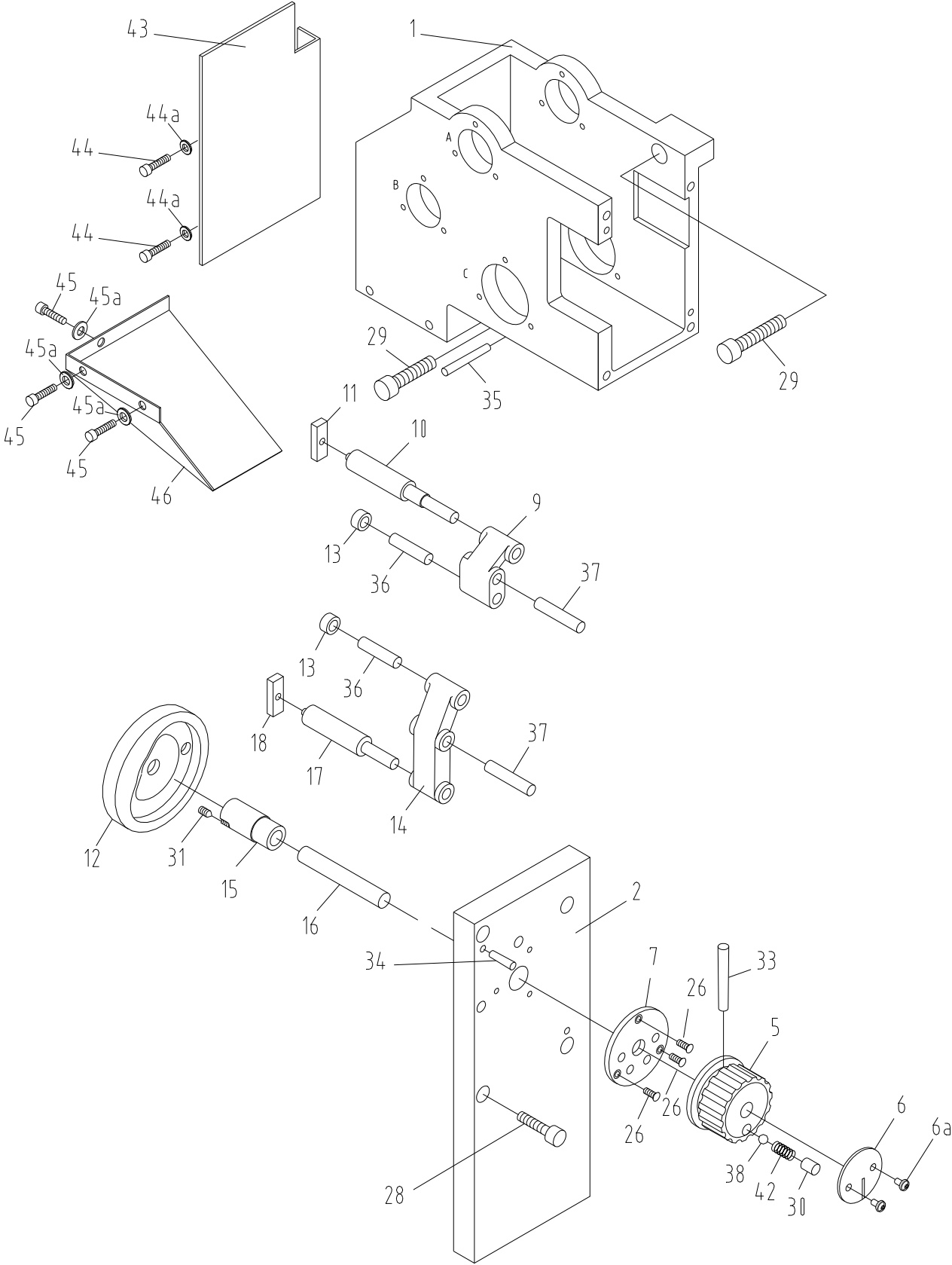

Change Gear Box Assembly I

Index No.	Part No.	Description	Size	Qty.
1	ZX08101-G	Change Gear Box Casting		1
2	ZX08108-G	Front Cover		1
5	ZX05104C-G	Hand Wheel		1
6	ZX05301C	Sign Plate (serial #16081100 and lower)		1
	C6136ZK02304-1	Sign Plate (serial #16081101 and higher)		1
6a	GB2672-M3x6	Screw (serial #16081101 and higher)	M3x6	2
7	ZX08708	Positioning Disc		1
9	ZX08111	Crank		1
10	ZX08705	Connecting Rod		1
11	ZX08304	Sliding Block		1
12	ZX05103C	Cam		1
13	ZX05702C	Roller		2
14	ZX08109	Crank		1
15	ZX08110	Bushing		1
16	ZX08704	Rotating Shaft		1
17	ZX08703	Connecting Rod		1
18	ZX08304	Sliding Block		1
26	ZXC26	Cross Head Screw	M4x12	3
28	TS1515031	Hex Socket Cap Screw	M8x25	4
29	TS1516051	Hex Socket Cap Screw	M10x40	2
30	TS1525021	Set Screw	M10x12	1
31	ZXC31	Flat Head Set Screw	M6x8	1
33	ZXC33	Taper Pin	4x45	1
34	ZXC34	Taper Pin	6x30	2
35	ZXC35	Taper Pin	6x50	1
36	ZXC36	Pin	10m6x40	2
37	ZXC37	Pin	10m6x50	2
38	ZXH5	Steel Ball	.8	1
42	ZXC42	Spring	1x8x30	1
43	ZX-08716-G	Splash Guard		1
44	GB818-M6x12	Cross Recessed Pen Head Screw	M6x12	2
44a	GB97.2-6	Flat Washer	6	2
45	GB818-M5x12	Cross Recessed Pen Head Screw	M5x12	3
46	ZX-08715	Splash Guard		1
45a	GB97.2-5	Flat Washer	5	3
46	ZX-08715-G	Splash Guard		1

Change Gear Box Assembly II

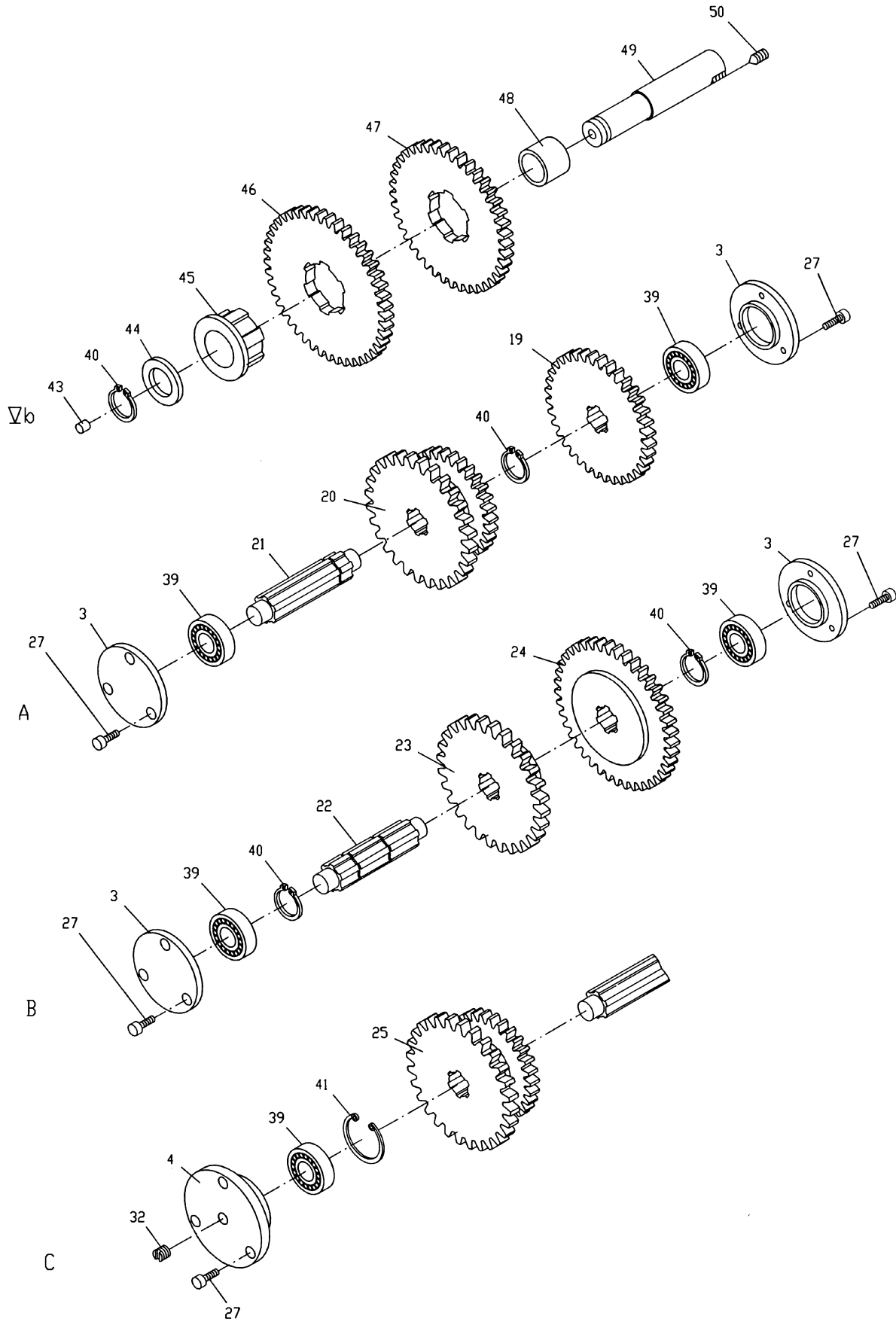

Change Gear Box Assembly II

Index No.	Part No.	Description	Size	Qty.
3	ZX08104-G	End Cover		4
4	ZX08103-G	Bearing Support		1
19	ZX08107	Gear	.3m36T	1
20	ZX08105	Double Gear	.3.75m28T/3m30T	1
21	ZX08702	Shaft		1
22	ZX08701	Shaft		1
23	ZX08710	Gear	.3.75m27T	1
24	ZX08709	Gear	.3m41T	1
25	ZX08102	Double Gear	.3.75m30T/3m29T	1
27	ZXC27	Slotted Cheese Head Screw	.M5x12	15
32	ZXC32	Flat Head Set Screw	.M10x12	1
39	BB6203	Ball Bearing	.17x40x12	5
40	ZXC40	C-Clip	.25	4
41	ZXC41	C-Clip	.40	1
43	ZXC43	Oil Cup	.8	1
44	TNMP08108	Washer		1
45	TNMP08102	Splinted Sleeve		1
46	TNMP08504	Gear	.3m45T	1
47	TNMP08501A	Gear (for 14"/16" models)	.3.5m35T	1
	TNMP08501B	Gear (for 18" models)	.4m35T	1
48	ZX05502C	Oil Bushing		1
49	ZX08707	Shaft Vb		1
50	ZXC50	Flat Head Set Screw	.M8x10	1

Quick Change Gear Box I

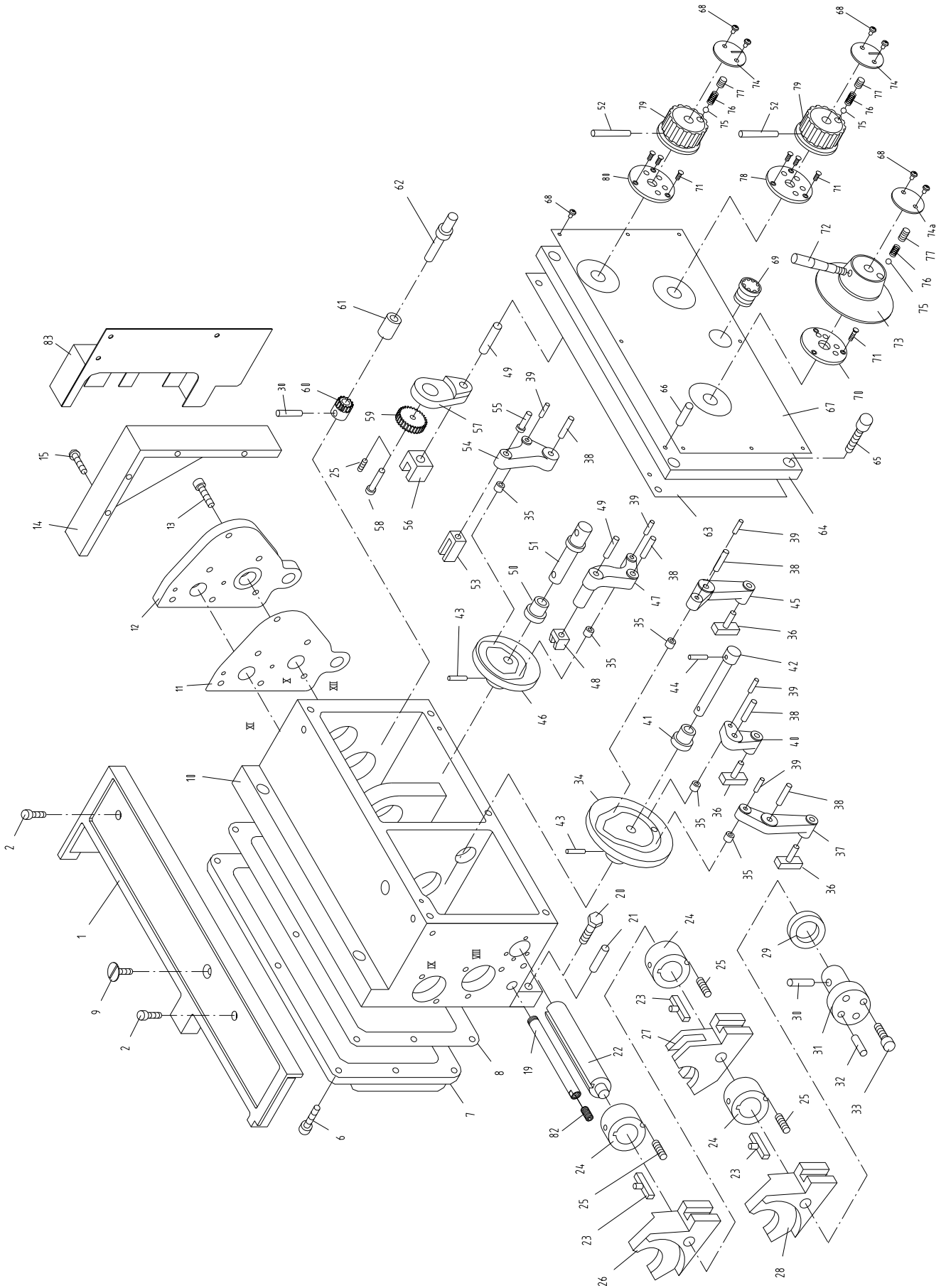

Quick Change Gear Box I

Index No.	Part No.	Description	Size	Qty.
1	KLS1740A05152-G	Upper Cover		1
2	TS1514051	Hex Socket Cap Screw	M6x22	2
6	TS1515011	Hex Socket Cap Screw	M8x16	10
7	ZX05109-G	Rear Cover		1
8	ZX05502	Gasket		1
9	ZXQ09	Countersunk Head Screw	M10x18	1
10	ZX05101-G	Feedbox Casting		1
11	ZX05501	Gasket		1
12	ZX05108-G	Flange		1
13	TS1515011	Hex Socket Cap Screw	M8x16	6
14	ZX05151-G	Extending Plate		1
15	TS1503131	Hex Socket Cap Screw	M6x60	4
19	ZXQ19	Pipe	M10x10	1
20	TS1491061	Hex Cap Bolt	M10x40	2
21	ZXH68	Taper Pin	6x35	2
22	ZX05738	Control Shaft		1
23	ZX05739	Sliding Key		3
24	ZX05128	Sliding Sleeve		3
25	ZXQ25	Flat Head Set Screw	M5x8	4
26	ZX05125	Right Fork		1
27	ZX05126	Middle Fork		1
28	ZX05127	Left Fork		1
29	ZXQ29	Ring Seal	32x3.1	1
30	ZXQ30	Taper Pin (serial #12090914 and lower)	4x25	2
	GB877-4x30	Taper Pin (serial #12090915 and higher)	4x30	2
31	ZX05129	Cover		1
32	ZXQ32	Pin	5n6x15	1
33	ZXQ33	Cheese Head Screw	M5x16	3
34	ZX05122	Cam		1
35	ZX05728	Rolling Sleeve		5
36	ZX05729	Poking Key		3
37	ZX05123	Crank		1
38	ZXQ38	Pin	8n6x32	5
39	ZXQ39	Pin	6n6x20	5
40	ZX05124	Crank		1
41	ZX05111	Sleeve		1
42	ZX05726	Lever Shaft		1
43	ZXQ43	Taper Pin (serial #12090914 and lower)	4x32	2
	GB877-4x35	Taper Pin (serial #12090915 and higher)	4x35	2
44	ZXQ44	Taper Pin	4x65	1
45	ZX05121	Crank		1
46	ZX05118	Cam		1
47	ZX05120	Crank		1
48	ZX05116	Fork		1
49	ZXQ49	Pin	8n6x18	2
50	ZX05117	Sleeve		1
51	ZX05737	Lever Shaft		1

Quick Change Gear Box I

Index	Part			
No.	No.	Description	Size	Qty.
52	ZXC33	Taper Pin	.4x45	2
53	ZX05115	Fork		1
54	ZX05119	Crank		1
55	ZX05735	Pin		1
56	ZX05112	Fork		1
57	ZX05113	Crank		1
58	ZX05730	Small Shaft		1
59	ZX05731	Big Gear	1m44T	1
60	ZX05732	Small Gear	1m22T	1
61	ZX05114	Sleeve		1
62	ZX05734	Lever Shaft		1
63	ZX05503	Gasket		1
64	ZX05110-G	Front Cover		1
65	TS1516011	Hex Socket Cap Screw	M10x20	5
66	ZXQ66	Taper Pin	.5x35	6
67	ZX05303A	Sign Plate (serial #16081100 and lower)		1
	GH1640ZX-08301-32	Sign Plate (serial #16081101 and higher)		1
68	ZXQ68	Cross Head Screw (serial #16081100 and lower)	M3x6	14
	GB2672-M3x6	Screw (serial #16081101 and higher)	M3x6	14
69	ZXQ69	Oil Sight Glass	.20	1
70	ZX05727	Positioning Disc		1
71	ZXQ71	Countersunk Head Screw	M4x12	9
72	ZX05740-G	Lever		1
73	ZX05130A-G	Lever Support		1
73a	1440R05303	Taper Label (not shown)		1
	GB827-2x3	Rivet (not shown)	.2x3	6
74	ZX05301	Sign Disc (serial #16081100 and lower)		2
	C6136ZK-02304-1	Sign Disc (serial #16081101 and higher)		2
74a	C6136-02306	Sign Disc		1
75	ZXH5	Steel Ball	.8	3
76	ZXQ76	Compression Spring	YZ-1x8x25	3
77	ZXH3	Flat End Set Screw	M10x12	3
78	ZX05736	Positioning Disc		1
79	ZX05140-G	Hand Wheel		2
80	ZX05733	Positioning Disc		1
81	C6136ZK05551	Rubber Washer		1
82	GB70-M8x5	Hex Socket Cap Screw	M8x5	1
83	1440R05752-G	Board		1

Quick Change Gear Box II

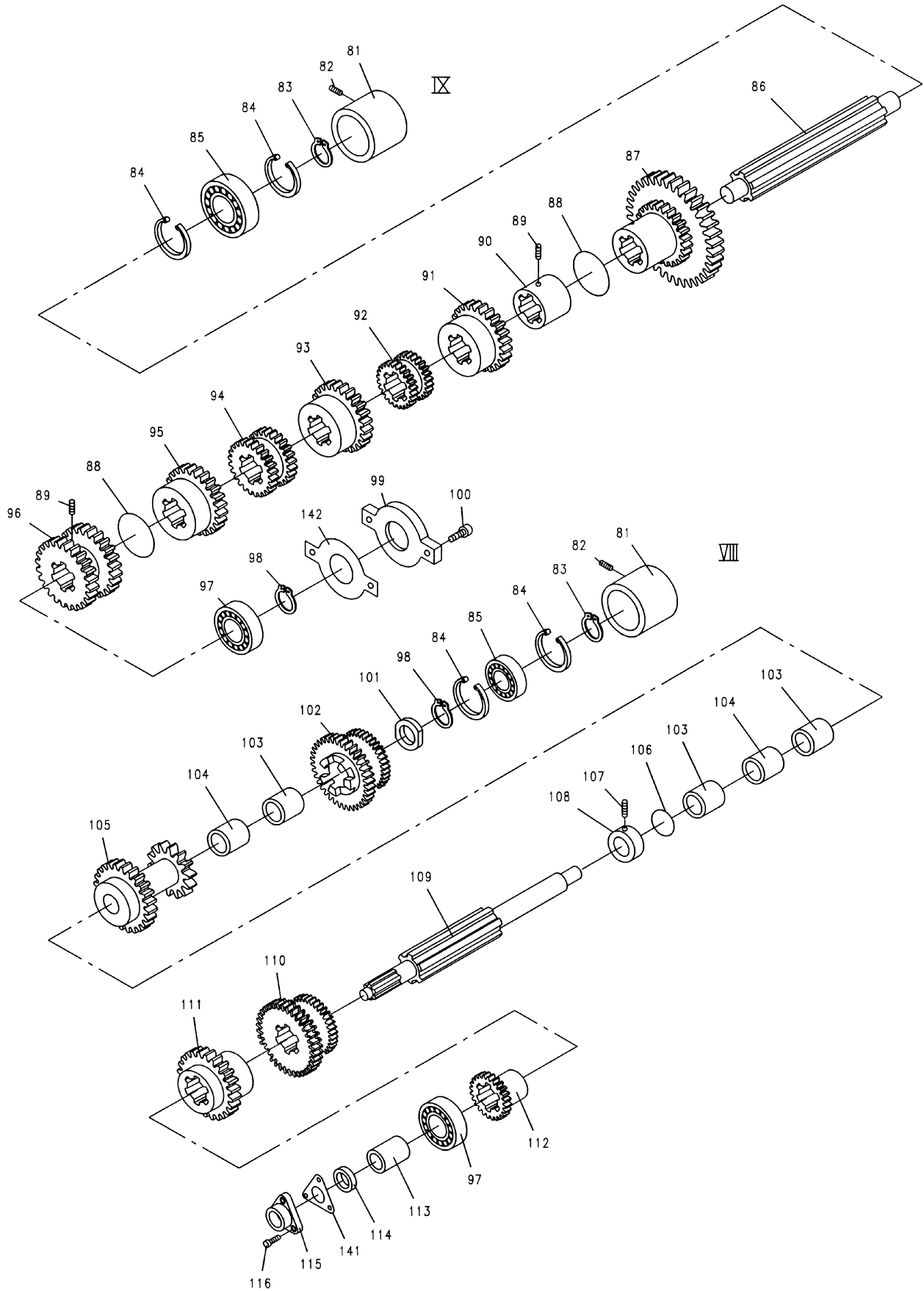

Quick Change Gear Box II

Index	Part			
No.	No.	Description	Size	Qty.
81	ZX05104	Middle Bearing Support		2
82	ZXQ82	Taper End Set Screw	M10x16	2
83	ZXB23	C-Clip	.20	3
84	ZXQ84	C-Clip	.42	5
85	BB6004	Single Row Radial Ball Bearing	.20x42x12	5
86	ZX05721	Shaft		1
87	ZX05722	Double Gear	.2m26T/2m52T	1
88	ZXQ88	Iron Wire	1x190	2
89	TS1524051	Set Screw	M8x20	2
90	ZX05720	Positioning Sleeve		1
91	ZX05719	Gear	.2.25m28T	1
92	ZX05718	Double Gear	.2m26T/2m28T	1
93	ZX05717	Gear	.3.5m20T	1
94	ZX05716	Double Gear	.3.5m18T/3.5m19T	1
95	ZX05715	Gear	.3.25m22T	1
96	ZX05714	Double Gear	.3.25m24T/3.25m23T	1
97	BB6205	Single Row Radial Ball Bearing	.25x52x15	2
98	ZXC40	C-Clip	.25	3
99	ZX05125-G	Shaft End Cover		1
100	TS1515011	Hex Socket Cap Screw	M8x18	2
101	ZX05704	Spacer		1
102	ZX05705	Double Gear	.2m52T/2m26T	1
103	ZX05502C	Oil Bushing		3
104	ZX05105	Sleeve		2
105	ZX05707	Double Gear	.2m39T/2m26T	1
106	ZXQ106	Iron Wire	1x160	3
107	TS1524031	Set Screw	M8x12	3
108	ZX05714C	Fixed Bushing		1
109	ZX05710	Shaft		1
110	ZX05709	Double Gear	.2m48T/2.25m42T	1
111	ZX05711	Sliding Gear	.3.5m24T	1
112	ZX05712	Sliding Gear	.3.25m24T	1
113	ZX05713	Sleeve		1
114	ZXG51-1	Spacer	.32	1
115	ZX05106-G	Bearing Support		1
116	TS1515031	Hex Socket Cap Screw	M8x25	3
141	ZX05504	Gasket		1
142	ZX05505	Gasket		1

Quick Change Gear Box III

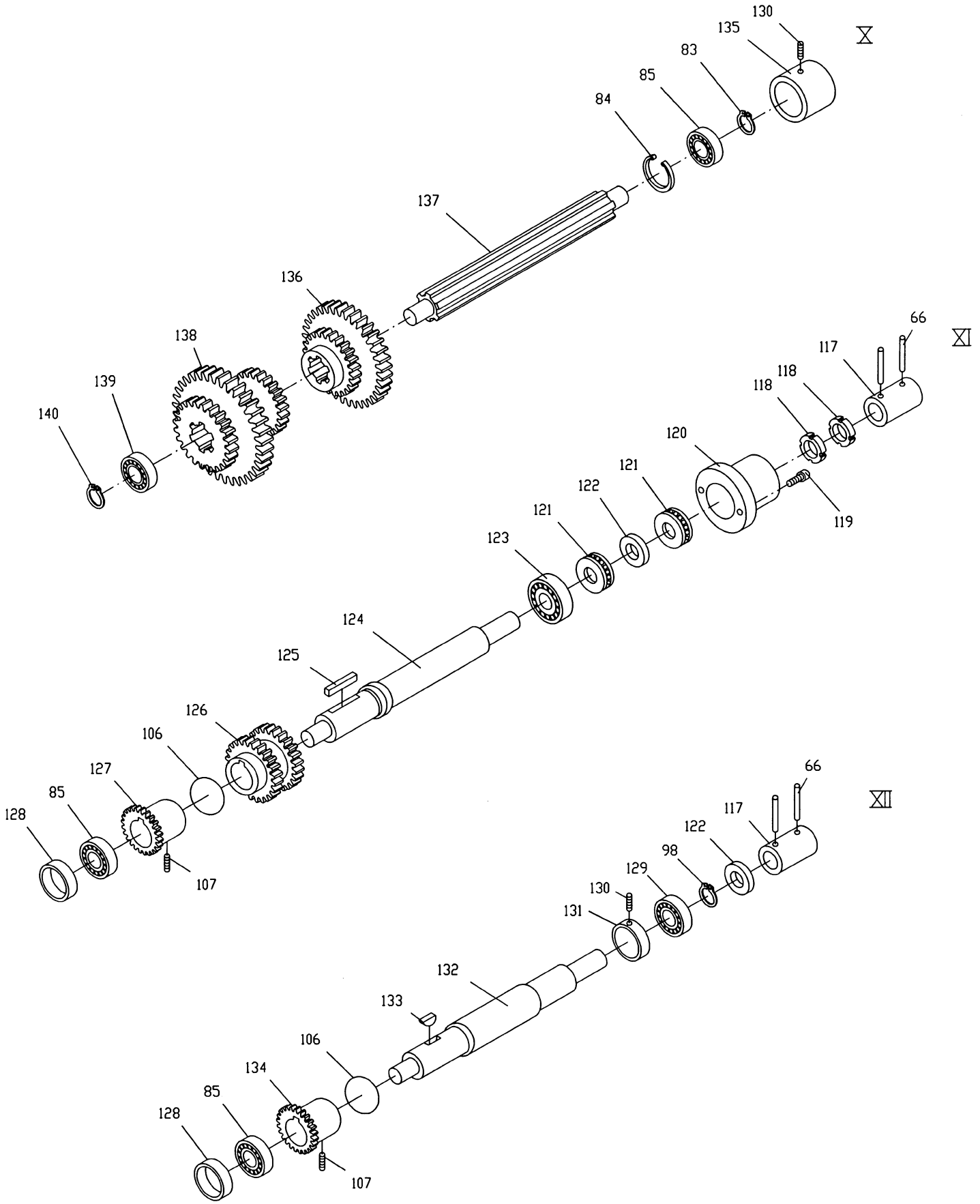

Quick Change Gear Box III

Index No.	Part No.	Description	Size	Qty.
66	ZXQ66	Taper Pin	.5x35	4
83	ZXQ83	C-Clip	.20	3
84	ZXQ84	C-Clip	.42	5
85	BB104	Single Row Radial Ball Bearing	.20x42x12	5
98	ZXQ98	C-Clip	.25	3
106	ZXQ106	Iron Wire	.1x160	3
107	TS1524031	Set Screw	M8x12	3
117	ZX05113C	Shaft Coupling		2
118	ZXQ118	Round Nut	M24x1.5	2
119	TS1503021	Hex Socket Cap Screw	M6x10	2
120	ZX05114-G	Cover		1
121	BB51105	Thrust Bearing	.25x42x11	2
122	ZXQ122	Spacer	.25	2
123	BB6305	Ball Bearing	.25x62x17	1
124	ZX05725	Shaft		1
125	ZXQ125	Key	.8x7x50	1
126	ZX05724	Double Gear	.2.25m35T/2.25m36T	1
127	ZX05723	Gear	.2.5m36T	1
128	ZX05107	Sleeve		2
129	BB6005	Ball Bearing	.25x47x12	1
130	TS1525021	Set Screw	M10x12	2
131	ZX05103	Bearing Support		1
132	ZX05701	Shaft		1
133	ZXQ133	Woodruff Key	.6x22	1
134	ZX05703	Gear	.2.5m36T	1
135	ZX05102	Bearing Support		1
136	ZX05702	Double Gear	.2.5m24T/2.25m35T	1
137	ZX05708	Shaft		1
138	ZX05706	Triple Gear	.2m39T/2m52T/2m26T	1
139	BB6203	Ball Bearing	.17x40x12	1
140	ZXQ140	C-Clip	.17	1

Apron Assembly I

Index No.	Part No.	Description	Size	Qty.
1	TL06101-G	Apron Casting		1
2	TL06103-G	Bottom Cover		1
3	TS1540072	Hex Nut	M10	1
4	ZXA04	Flat Head Set Screw	M10x70	1
5	TL06502	Cushion Cap		1
6	ZXA06	Pin	6n6x16	2
7	ZXA07	Tensile Spring	Y11.2x9x50	1
8	TL06734	Lever		1
9	ZXA09	Pin	8n6x30	1
10	ZXA10	Pin	6n6x18	1
11	TL06701-A	Pushing Rod		1
12	ZXA12	Oil Seal	15x2.4	1
13	BB60016	Ball Bearing	6x17x6	1
14	ZXA06	Pin	6n6x16	1
15	GB70	Hex Socket Cap Screw	M8×6	1
16	ZXB34	Taper Pin	5x30	2
17	TS1504041	Hex Socket Cap Screw	M8x20	6
18	TL06501	Gasket		1
19	TL06307	Sign Plate (serial #16081100 and lower)		1
	C0632B05302-2	Sign Plate (serial #16081101 and higher)		1
19a	GB2672-M3x6	Screw (serial #16081101 and higher)	M3x6	6
20	ZX02741-G	Handle		1
21	ZX06122-G	Lever Support		1
22	ZXB27	Taper Pin	6x60	1
23	TL06717	Half Nut Shaft		1
24	TL06111	Positioning Block		1
25	ZXA25	Thread Tail Taper Pin	6x25	1
26	TS1523031	Set Screw	M6x10	1
27	ZX06733	Half Nut Control Plate		1
28	ZXA28	Taper Pin	6x55	1
29	ZX06732	Pin		2
30	ZX06302NE	New Half Nut		1
31	TS1540072	Hex Nut	M10	1
32	ZXA32	Cylindrical End Set Screw	M10x60	1
33	ZX06121	Gib		1
34	ZX06731	Cylindrical End Set Screw		3
35	TS1540061	Hex Nut	M8	3
36	ZXA36	Set Screw	M8x32	1
37	ZXA37	Oil Sight Glass	20	1
69	TL06727N	New Gear	2m25T	1
70	TL06728	Sliding Key		2
71	TL06121N	New Spacer		2
72	TL06304N	New Positioning Sleeve		2
73	ZXA73	Ring Seal For Rotating	3x55	2
74	ZXA74	Oil Seal	35x3.1	1
75	TL06729N	New Sleeve		1

Apron Assembly I

Index No.	Part No.	Description	Size	Qty.
122	1440R06302	Sign Plate (serial #16081100 and lower)		1
	GH1640ZX06302B-11	Sign Plate (serial #16081101 and higher)		1
123	TL06730	Shaft		1
124	BB51104	Thrust Bearing		2
125	TL06305	Sleeve		2
126	TL06726N	New Worm		1
127	TL06122N	New Worm Support		1
128	TL06720	Control Plate		1
129	TS1514031	Hex Socket Cap Screw	M6x20	4
130	ZXA130	Taper Pin	4x20	1
131	TS1524031	Set Screw	M8x12	2
132	ZXA132	Screw	M8x25	2
133	ZXA133	Cylindrical Tensile Spring	LI-1.6x10x58	1
134	TL06503	Gasket		1
135	TL06114-G	Back Cover		1
136	TS1514011	Hex Socket Cap Screw	M6x12	5
137	ZXA137	Set Screw	M8x30	2
138	ZXA138	Iron Wire	1x50	2
139	ZXA139	Oil Conducting Cord	3x100	2
140	ZXA140	Screw	M10x40	1
158	TS1540041	Hex Nut	M6	1
159	TL06124	Bracket		1
160	ZXA160	Taper Pin	5x25	2
161	TL06308-G	Bracket		1
162	TS1503041	Hex Socket Cap Screw	M6x16	1
163	TL06120	Sleeve		1

Apron Assembly II

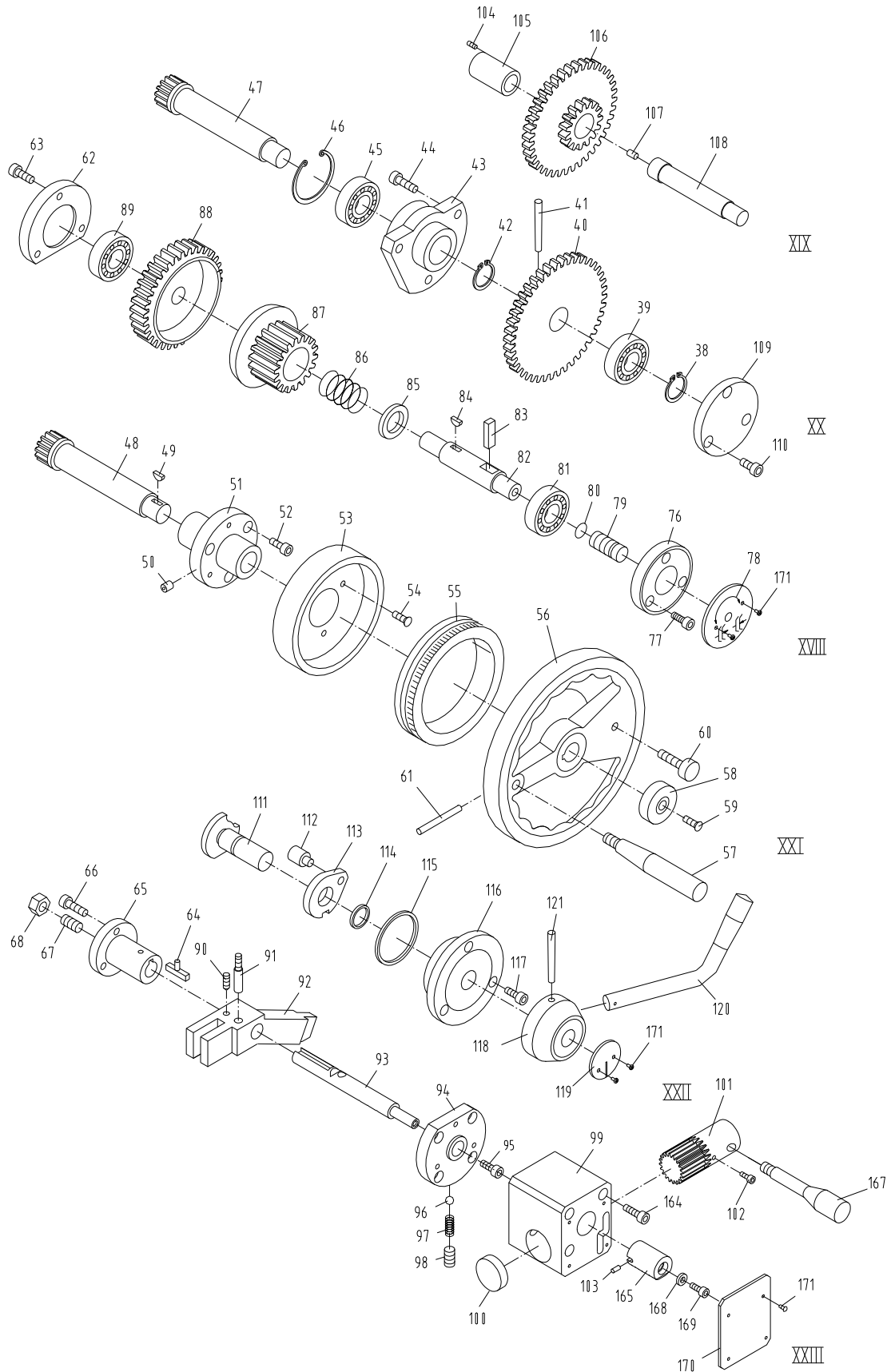

Apron Assembly II

Index	Part			
No.	No.	Description	Size	Qty.
38	ZXB23	C-Clip	20	1
39	BB6204	Ball Bearing	20x47x14	1
40	TL06705 (m)	Gear	2m66T	1
41	ZXA41	Taper Pin (serial #12090914 and lower)	6x40	1
	GB877-6x45	Taper Pin (serial #12090915 and higher)	6x45	1
42	ZXC40	C-Clip	25	1
43	ZX06127N	New Bearing Support		1
44	TS1504041	Hex Socket Cap Screw	M8x18	3
45	BB6205Z	Ball Bearing	25x52x15	1
46	ZXA46	C-Clip	52	1
47	TL06704N	New Shaft	2m14T	1
48	TL06706	Hand Wheel Shaft	2mx15T	1
49	ZXH10	Half Circle Key	4x16	1
50	ZXA50	Oil Cup	8	1
51	TL06104	Lever Support		1
52	TS1514031	Hex Socket Cap Screw	M6x18	3
53	TL06105E	Dial Support		1
54	ZXA54	Cross Head Screw	M5x12	3
55	TL06732E	Dial		1
56	TL06107-G	Hand Wheel		1
57	ZX06710-G	Shaft Driven Lever		1
58	TL06709	Shaft Cover		1
59	ZXA54	Cross Head Screw	M5x12	1
60	TL06708	Screw		1
61	TL06707	Pin		1
62	TL06112	End Cover		1
63	TS1514011	Hex Socket Cap Screw	M6x12	3
64	TL06733	T Shaped Flat Key		1
65	TL06115	Flange Sleeve		1
66	TS1514011	Hex Socket Cap Screw	M6x12	3
67	ZXA67	Flat End Set Screw	M6x30	1
68	TS1540041	Hex Nut	M6	1
76	TL06109-G	Flange		1
77	TS1514011	Hex Socket Cap Screw	M6x12	3
78	TL06303	Sign Plate (serial #16081100 and lower)		1
	TL06303-1	Sign Plate (serial #16081101 and higher)		1
79	TL06714	Adjusting Screw		1
80	ZXA80	Oil Seal	8x1.9	1
81	BB7203	Ball Bearing	17x40x12	1
82	TL06713	Shaft		1
83	TL06715	Adjusting Rod		1
84	ZXH10	Woodruff Key	4x16	1
85	TL06712	Spring Cover		1
86	ZXA86	Spring	Y1-4x32x40	1
87	TL06718	Gear	2m28T	1
88	TL06113	Helical Gear	2.5m40T	1
89	BB7006/P6	Ball Bearing	30x55x13	1

Apron Assembly II

Index	Part			
No.	No.	Description	Size	Qty.
90	TS1523031	Set Screw	M6x10	1
91	ZXA25	Thread Tail Taper Pin	6x25	1
92	TL06110	Fork		1
93	ZX06721E	Control Rod		1
94	ZX06116E-G	Lever Support		1
95	ZXA95E	Cross Head Screw	M6x30	1
96	ZXH5	Steel Ball	8	1
97	ZXA97	Spring	Y1-1x7x25	1
98	ZXA98	Flat Head Set Screw	M10x16	1
99	ZX06737E	Bracket		1
100	ZX06741E	Plug		1
101	ZX06739E-G	Gear Shaft		1
102	ZXA102E	Hex Head Screw	M4x8	1
103	ZXA103E	Pin	4x8	1
104	ZXA104	Flat Head Set Screw	M4x8	1
105	TL06301	Sleeve		1
106	TL06710	Gear	2m21T/2m57T	1
107	ZXA107	Pin	6n6x8	1
108	TL06711	Shaft		1
109	TL06108-G	End Cover		1
110	TS1514011	Hex Socket Cap Screw	M6x12	3
111	TL06723	Control Shaft		1
112	TL06725	Pin		1
113	TL06724	Control Block		1
114	ZXA114	Oil Seal	20x2.4	1
115	ZXA115	Oil Seal	50x3.1	1
116	TL06119	Lever Flange		1
117	TS1514011	Hex Socket Cap Screw	M6x12	3
118	TL06118-G	Lever Support		1
119	TL06307	Sign Plate (serial #16081100 and lower)		1
	C0632B05302-2	Sign Plate (serial #16081101 and higher)		1
120	ZXK06722-G	Lever		1
121	ZXB27	Taper Pin	6x60	1
164	ZXA164E	Hex Head Screw	M6x35	3
165	ZX06738E	Rack		1
167	ZX06740E-G	Handle		1
168	ZX06736E	Washer		1
169	ZXA169E	Hex Head Screw	M5x10	1
170	ZX06303E	Label (serial #16081100 and lower)		1
	GH1640ZX06303-3	Label (serial #16081101 and higher)		1
171	ZXA171E	Screw (serial #16081100 and lower)	M3x5	8
	GB2672-M3x6	Screw (serial #16081101 and higher)	M3x6	8

Apron Assembly III

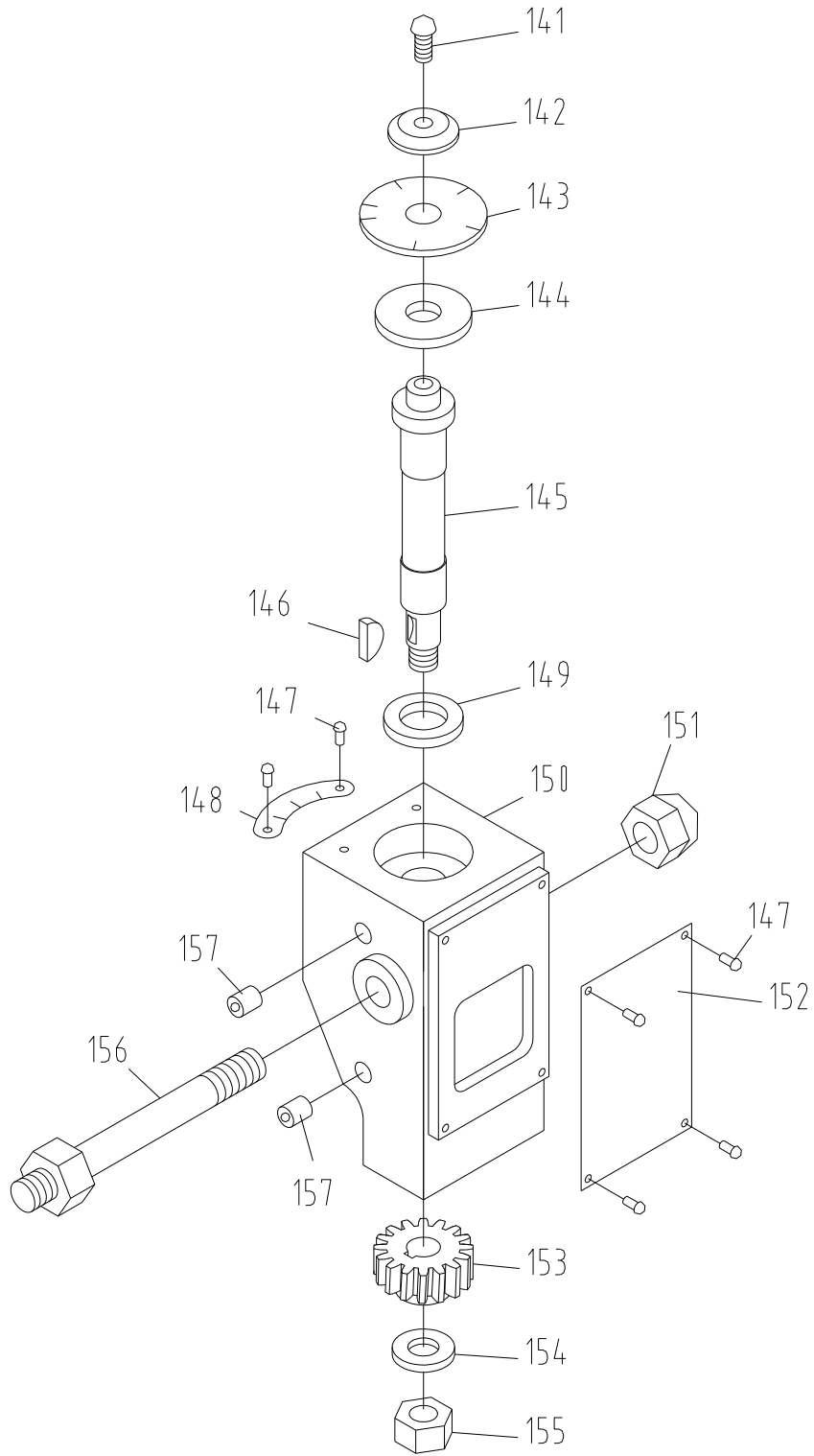

Apron Assembly III

Index	Part	Description	Size	Qty.
No.	No.			
141	ZXA141	Half Round Head Screw	M6x18	1
142	ZX11704	Washer		1
143	ZX11301	Dial (serial #16081100 and lower)		1
	ZX11302-3	Dial (serial #16081101 and higher)		1
144	ZX11105	Adjusting Washer		1
145	ZX11701	Shaft		1
146	ZXH10	Half Circle Key	.4x16	1
147	ZXA147	Half Round Head Screw (serial #16081100 and lower)	M3x6	6
	GB2672-M3x6	Screw (serial #16081101 and higher)	M3x6	6
148	ZX11303	Positioning Sign Plate		1
149	ZX11703	Adjusting Washer		1
150	ZX11101-G	Casting		1
151	ZXA151	Acorn Nut	M12	1
152	ZX11304	Thread Chasing Label (serial #16081100 and lower)		1
	ZX11304-2	Thread Chasing Label (serial #16081101 and higher)		1
153	ZX11102E	Helical Gear	.2m15T	1
154	TS1550071	Flat Washer	M10	1
155	TS1540072	Hex Nut	M10	1
156	ZX11702	Bolt		1
157	ZXA157	Oil Cup	.8	2

Carriage Assembly

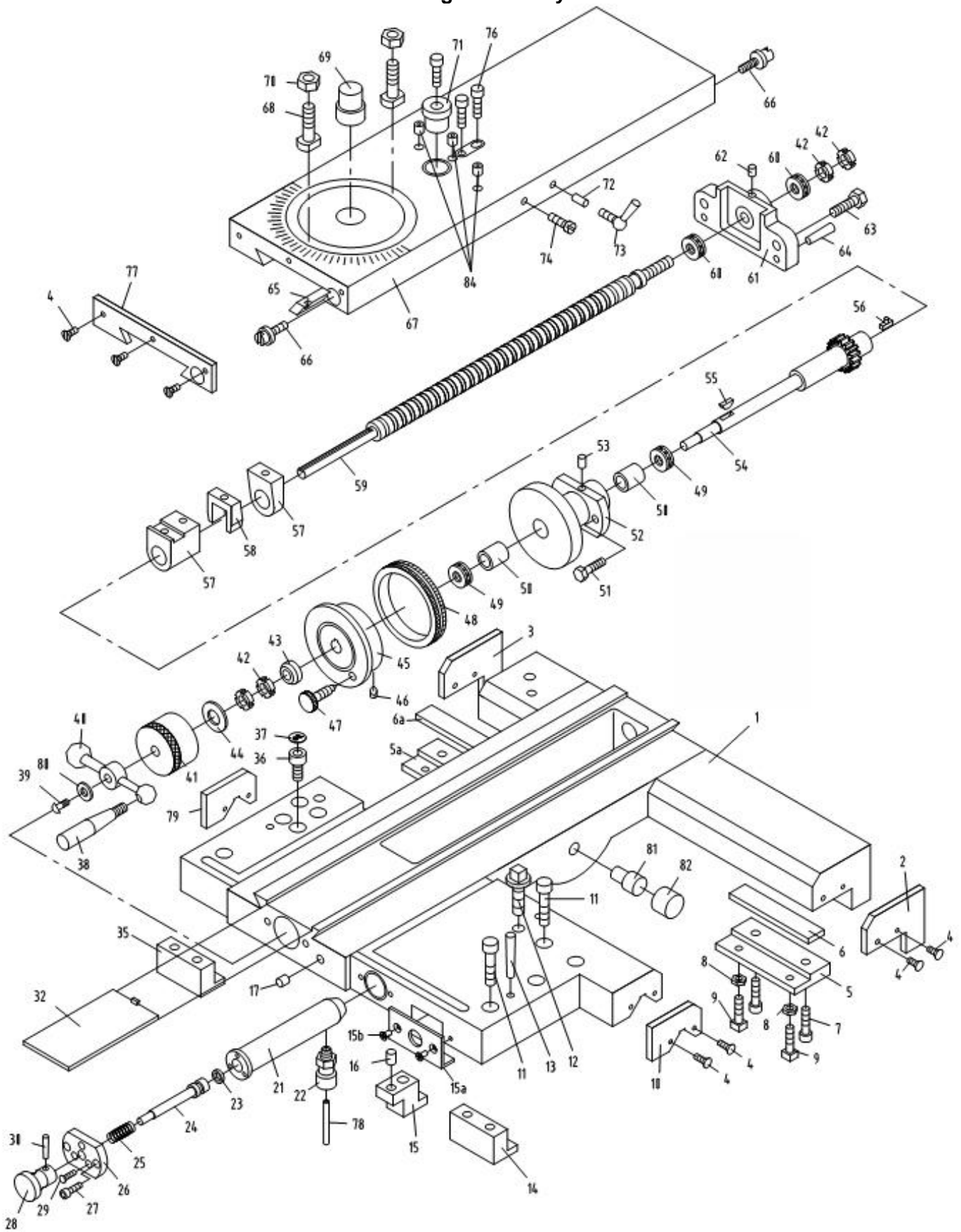

Carriage Assembly

Index No.	Part No.	Description	Size	Qty.
1	ZX K04101A-B	Saddle Casting (for 14" /16" /18" models) (serial #16051084 and lower)		1
	ZX 04101B	Saddle Casting (for 14" /16" /18" models) (serial #16081085 and higher)		1
2	ZX04505J	Wipe Plate		1
3	ZX04504J	Wipe Plate		1
4	ZXC04	Half Round Head Screw	M5x16	11
5	ZX04724	Clamping Block		1
5a	ZX04724	Clamping Block (serial #16051084 and lower)		1
	1440R04724A	Clamping Block (serial #17011109 and lower)		1
	1440R04724AE	Clamping Block (serial #17051110 and higher)		1
6	ZX04113	Lining Plate		1
6a	ZX04113	Lining Plate (serial #16051084 and lower)		1
	1440R04113J	Lining Plate (serial #16081085 and higher)		1
7	TS1516031	Hex Socket Cap Screw	M10x30	4
8	TS1540061	Hex Nut	M8	4
9	ZXCA09	Square Set Screw	M8x20	4
10	ZX04506J	Wipe Plate		1
11	TS1505071	Hex Socket Cap Screw	M10x45	8
12	ZXCA12	Square Cap Bolt	M12x70	1
13	ZXCA13	Taper Pin	.8x60	2
14	ZX04729	Clamping Block		1
15	ZX04730	Locking Plate		1
15a	1440R04793J	Button Support (serial #16081085 and higher)		1
15b	GB819-M5x12	Countersunk Head Screw (serial #16081085 and higher)	M5x12	2
16	ZXCA16	Pin	.4n6x12	1
17	ZX04772	Blocking Piece		1
21	ZX04782	Manual Oil Pump Casting		1
22	ZX04781A	In Valve		1
23	ZXCA23	Oil Ring	15x2.4	1
24	ZX04784	Piston		1
25	ZXCA25	Spring	1.2x14x65	1
26	ZX04785-G	Oil Pump Cover		1
27	TS1513031	Hex Socket Cap Screw	M5x16	2
28	ZX04783-G	Lever		1
29	ZXCA29	Countersunk Head Screw	M4x16	3
30	ZXA130	Taper Pin	.4x20	1
32	ZX04716	Chip Guard		1
35	ZX04740	Clamping Block		1
36	ZX04750	Oil Cap		1
37	ZX04301	Oil Indicator Cap		1
38	ZX04721-G	Lever		1
39	ZXCA39	Cross Head Screw	M5x16	1
40	ZX04720-G	Handle		1
41	ZX04769-G	Sleeve		1
42	ZXCA42	Round Nut	M12x1.25	4
43	ZX04719	Lining		1
44	ZX04770	Disc Spring		1
45	ZX04108-G	Flat Pan		1

Carriage Assembly

Index	Part			
No.	No.	Description	Size	Qty.
46	ZX04790	Pushing Rod		1
47	ZX04789	Screw		1
48	ZX04717E	Dial		1
49	BB51102	Thrust Bearing	.15x28x9	2
50	ZX04111	Sleeve		2
51	TS1490041	Hex Cap Bolt	M8x25	2
52	ZX04109E	Screw Support		1
53	ZXCA53	Oil Cup	.8	1
54	ZX04707-1	Gear Sliding Sleeve	.2m16T	1
55	ZXH10	Woodruff Key	.4x16	1
56	ZX04751	Flat Key		1
57	ZX04302E	Nut Assembly		1
58	ZX04748	Wedge		1
59	ZX04707-2E	Lead Screw		1
60	BB51101/P6	Thrust Bearing	.12x26x9	2
61	ZX04116-B-G	Bracket		1
62	ZXCA62	Oil Cup	.6	1
63	TS1491041	Cap Screw	M10x30	2
64	ZXCA64	Taper Pin	.8x30	2
65	ZX04731	Cross Slide Gib		1
66	ZX04725C	Screw		2
67	ZX04102A	Cross Slide		1
68	ZX04714	Screw (for 18" models, T- Slot)		2
	ZX04714C	Screw (for 14" /16" models, T-Slot)		2
69	ZX04732	Pin		1
70	TS1540081	Hex Nut	M12	2
71	ZX04709	Sleeve		1
72	ZX-04304	Pressing Pin (for 14" models only)		1
73	ZX-04746-G	Screw (for 14" models only)		1
74	ZX-04786-G	Set Screw (for 14" models only)		1
76	ZXC76	Socket Head Cap Screw	M8x22	3
77	ZX04502J	Wipe Plate		1
78	ZXCA78	Copper Tube		6
79	ZX04503J	Wipe Plate		1
80	ZX04771-G	Lining		1
81	ZX04788	Stop Pin		1
82	ZX04507	Stop Pin Cap		1
84	ZXCA84	Oil Cup	.10	3
85	ZXCA85	Turcite-B (not shown)	.550x50x0.8	1
86	ZXCA86	Turcite-B (not shown)	.550x25x0.8	2

Carriage Stop Assembly

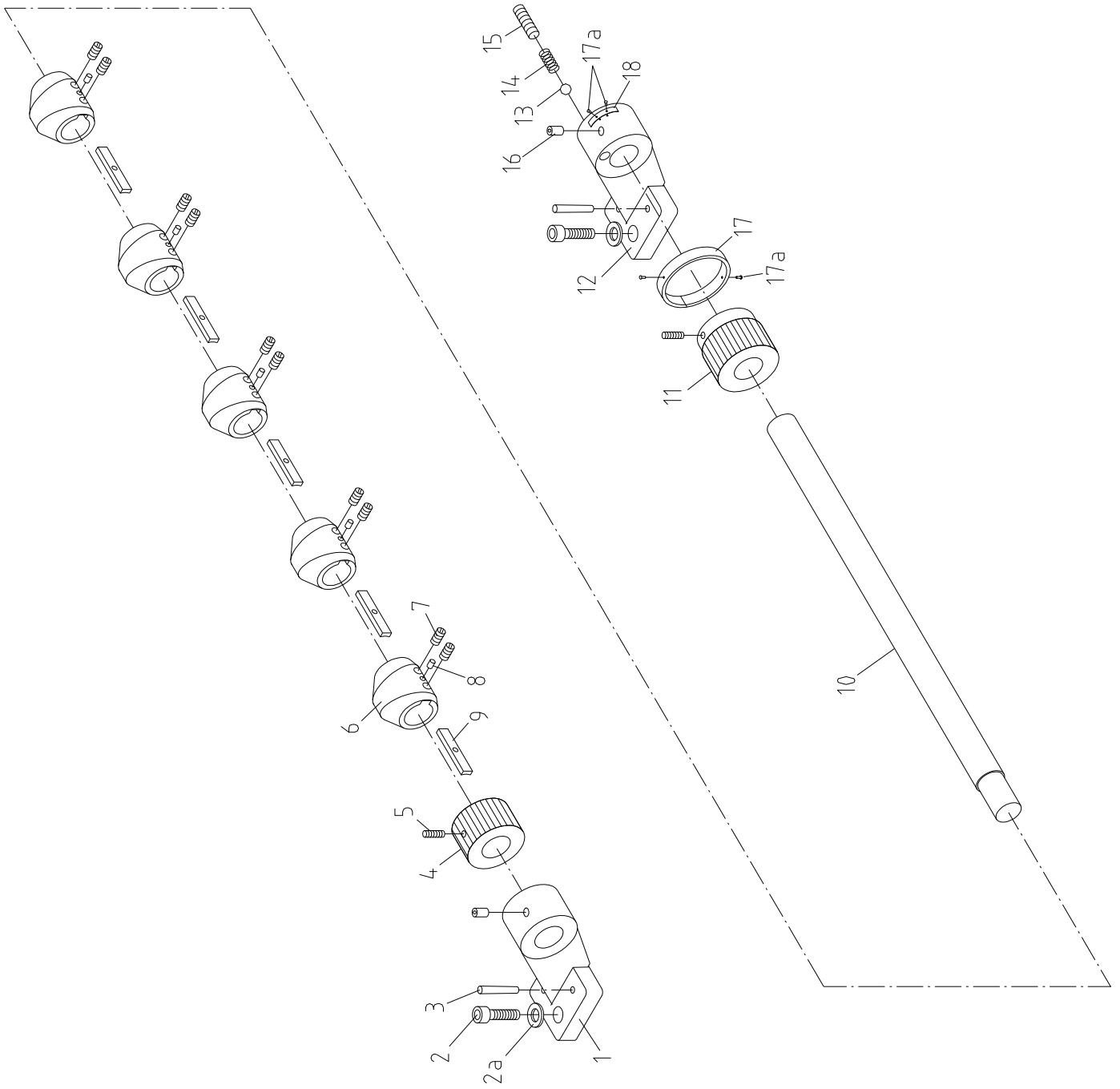

Carriage Stop Assembly

Index No.	Part No.	Description	Size	Qty.
1	ZX26101-G	Left Support		1
2	TS1504041	Hex Socket Cap Screw	M8x20	4
2a	GB5287-8	Thick Washer	.8	4
3	ZXC34	Taper Pin	.6x30	4
4	ZX26704-G	Control Ring		1
5	TS1523031	Set Screw	M6x10	2
6	ZX26702	Eccentric Travel Setting Ring		5
7	ZXH66	Flat End Set Screw	M6x10	10
8	ZXCS08	Pin	.4n6x10	5
9	ZX26703	Locking Key		5
10	ZX26701A	Travel Setting Rod (for 1440/1640/1840ZX)		1
	ZX26701B	Travel Setting Rod (for 1660/1860ZX)		1
	ZX26701C	Travel Setting Rod (for 1880ZX)		1
11	ZX26705-G	Control Ring		1
12	ZX26104-G	Right Support		1
13	ZXH5	Steel Ball	.8	1
14	ZXCS14	Compression Spring	.2x8x25	1
15	ZXCS15	Flat Head Set Screw	M10x12	1
16	ZXCS16	Oil Cup	.8	2
17	ZX26301	Dial		1
17a	GB867-3x8	Dial	.3x8	4
18	C6136ZK03303B	Plate		1

Four Way Tool Post

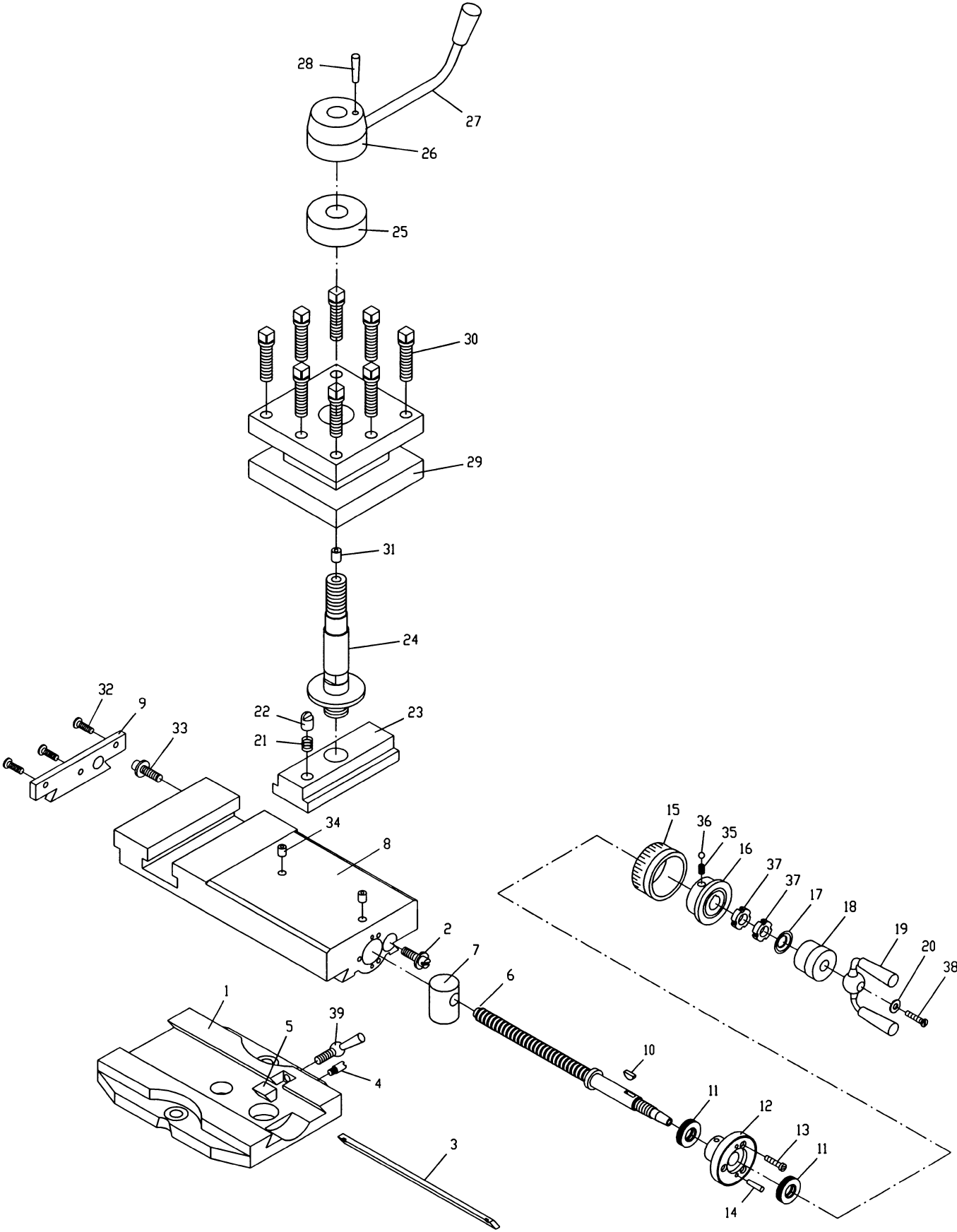

Four Way Tool Post

Index No.	Part No.	Description	Size	Qty.
1	ZX-04103A	Revolving Plate (for 14" models)		1
	ZX04103B	Revolving Plate (for 16" models)		1
	ZX04103C	Revolving Plate (for 18" models)		1
2	ZX04725	Screw		1
3	ZX04710	Gib		1
4	ZX04786-G	Screw		1
5	ZX04303	Pressing Block		1
6	ZX04706E	Lead Screw		1
7	ZX04106AE	Nut		1
8	ZX-04107A	Top Slide (for 14" models)		1
	ZX04107B	Top Slide (for 16" /18" models)		1
9	ZX04501	Wipe Plate		1
10	ZXF10	Woodruff Key	.3x13	1
11	BB51102	Thrust Bearing	15x28x9	2
12	ZX04115E	Sleeve		1
13	ZXF13	Slotted Cheese Head Screw	M5x12	3
14	ZXF14	Taper Pin	.3x18	2
15	ZX04727E	Dial		1
16	ZX04114	Sleeve		1
17	ZX04768	Disc Spring		1
18	ZX04767-G	Sleeve		1
19	ZX04726-G	Handle		1
20	ZX04771-G	Lining		1
21	ZX04763	Spring	0.8x6x25	1
22	ZX04787	Positioning Block		1
23	ZX04752A	T-Slot Nut		1
24	ZX04754	Shaft		1
25	ZX04759-G	Adjusting Lining Sheet		1
26	ZX04110-G	Lever Support		1
27	ZX04753-G	Handle		1
28	ZXQ66	Taper Pin	.5x35	1
29	ZX-04713A	Tool Post (for 14" models)		1
	ZX04713B	Tool post (for 16" /18" models)		1
30	ZXF30A	Clamping Screw (for 16" /18" models)	M12x45	8
	ZX-F30B	Clamping Screw (for 14" models)	M12x50	8
31	ZXF31	Oil Cup	.8	1
32	ZXH211	Countersunk Head Screw	M5x16	3
33	ZX04725C	Screw		1
34	ZXF34	Oil Cup	.8	2
35	ZXF35	Spring	0.7x5x9	2
36	ZXF36	Steel Ball	.6	2
37	ZXF37	Round Nut	M12x1.25	2
38	ZXCA39	Cross Head Screw	M5x16	1
39	ZX04746K-G	Screw Wrench		1
	ZXTA14/16/18-G	Toolholder Assy. (includes # 29 & 30)		
	ZXCPA14-G	Compound Assy. 14" (includes # 1-20, 32-39)		
	ZXCPA16-G	Compound Assy. 16" (includes # 1-20, 32-39)		
	ZXCPA18-G	Compound Assy. 18" (includes # 1-20, 32-39)		

Tailstock Assembly I

Index No.	Part No.	Description	Size	Qty.
1	ZX03711-G	Handle		1
2	ZX03717-G	Lever Support		1
3	ZX03718	Washer		1
4	ZX03719	Clamping Block		1
5	ZX03720	Clamping Block		1
6	ZXT06	Cylindrical End Set Screw	M8x14	2
7	ZX03712	Eccentric Shaft		1
10	ZX03701A	Center Sleeve (for 18" models)		1
	ZX03701B	Center Sleeve (for 14" / 16" models)		1
11	ZXT11	Ring Seal	75x2.65	1
12	ZX03703	Front Cover		1
13	ZXT13	Cross Recessed Countersunk Head Screw	M5x10	4
14	ZXT14A	Center Morse (for 18" models)	No.5	1
	ZXT14B	Center Morse (for 14" /16" models)	No.4	1
22	ZX03702	Positioning Block		1
35	ZX03714C	Eccentric Shaft		1
36	ZXT36	Taper Pin	6x32	1
37	ZX03104-G	Lever Sleeve		1
38	ZX03709-G	Lock Handle		1
39	ZXA28	Taper Pin	6x55	1
40	TS1504041	Hex Socket Cap Screw	M8x20	4
41	TS1515031	Hex Socket Cap Screw	M8x22	3
42	ZXT42	Pin	10n6x22	1
43	ZX03302	Sign Plate		1
45	ZXT45	Nail	3x8	4
46	ZX03105E	Nut		1
47	BB51205	Thrust Ball Bearing	25x47x15	1
48	ZX03104E	Back Cover		1
49	ZX03103-G	Hand Wheel		1
50	ZX03707-G	Lever		1
51	ZXT51	Acorn Nut	M16	1
52	TS2360161	Flat Washer	B16	1
53	ZXT53	Key	6x40	1
54	ZX03710AE	Lead Screw (for 18" models)		1
	ZX03710BE	Lead Screw (for 14/16" models)		1
55	ZX03101A-G	Tailstock Casting (for 18" models)		1
	ZX03101B-G	Tailstock Casting (for 16" models)		1
	ZX03101C-G	Tailstock Casting (for 14" models)		1
56	ZXT56	Oil Cup	8	1
57	ZX03708E	Dial		1
58	ZX03706	Sleeve		1
59	ZX03711C	Spring Leaf		1
65	TS2310162	Nut	M16	1

Tailstock Assembly II

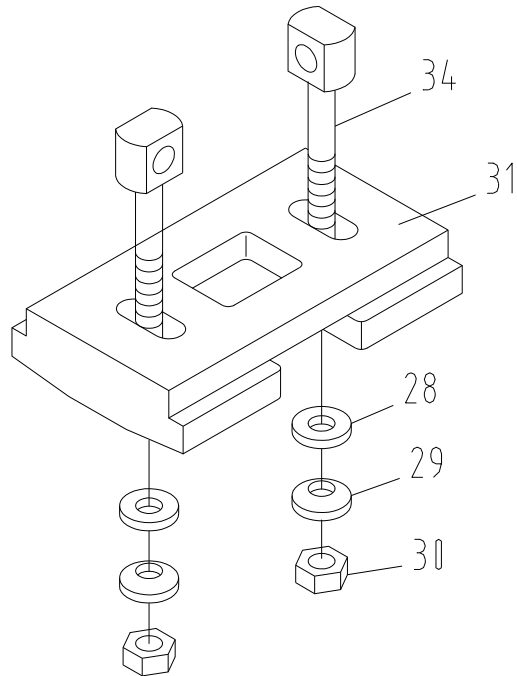
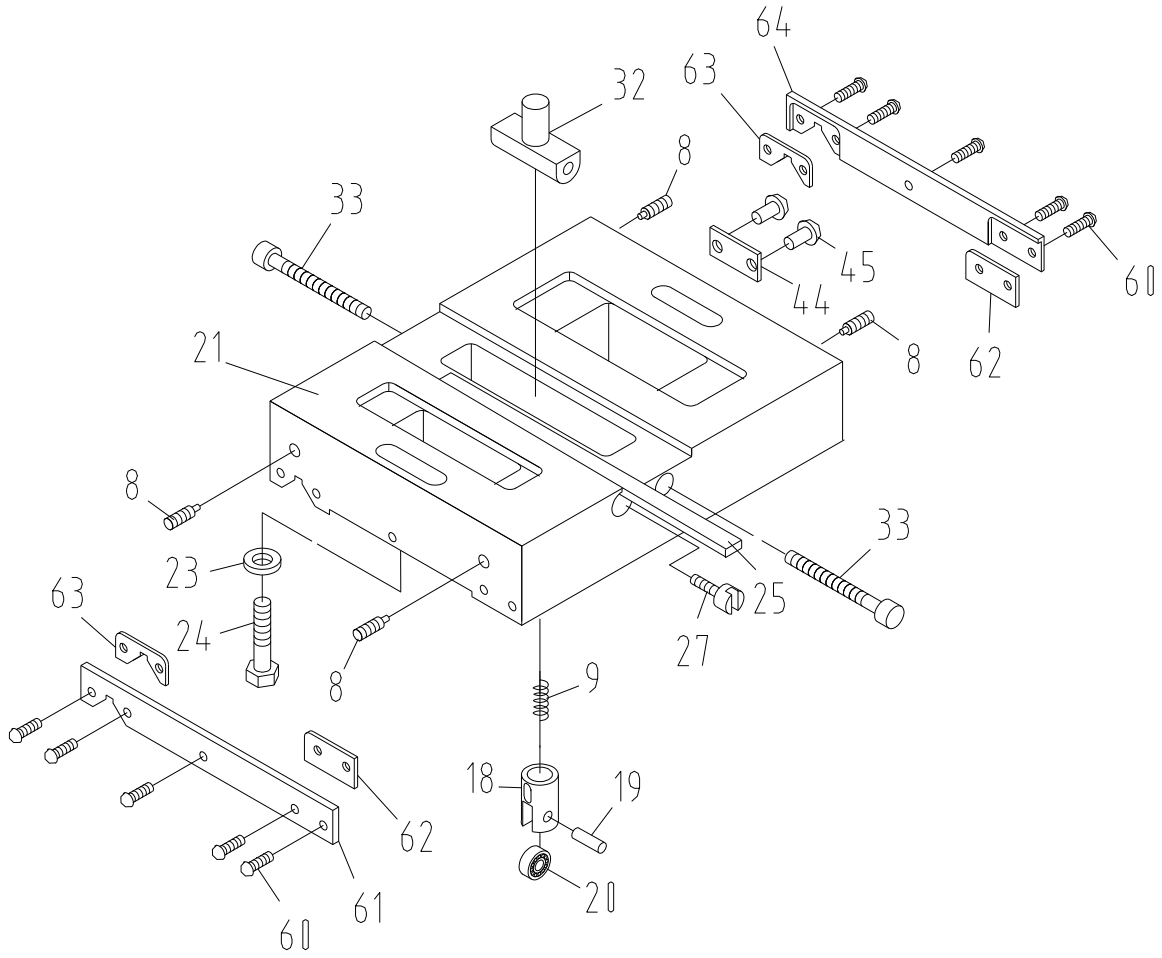

Tailstock Assembly II

Index No.	Part No.	Description	Size	Qty.
8	ZXT08	Flat End Set Screw	M6x18	4
9	ZXT09E	Spring (except in 14" models)		1
18	ZX03714	Bearing Support (except in 14" models)		4
19	ZX03715	Small Axle (except in 14" models)		4
20	ZXT20	Ball Bearing (except in 14" models)	7x19x6	4
21	ZX03102A-G	Sliding Base (for 18" models)		1
	ZX03102B-G	Sliding Base (for 16" models)		1
	ZX03102C-G	Sliding Base (for 14" models)		1
23	TS1550071	Flat Washer	10	2
24	TS1491151	Hex Cap Bolt (for 18" models)	M10x90	2
	TS1491121	Hex Cap Bolt (for 16" models)	M10x70	2
	TS1491081	Hex Cap Bolt (for 14" models)	M10x50	2
25	ZX03704	Gib		1
27	ZX03718C	Adjusting Screw		2
28	ZXT28	Taper Washer	16	2
29	ZXT29	Spherical Washer	16	2
30	TS2310162	Hex Nut	M16	2
31	ZX03106-G	Clamping Bracket		1
32	ZX03105C	Nut		1
33	ZXT33	Hex Socket Cap Screw (full thread)	M8x90	2
34	ZX03705A	Pulling Rod (for 18" models)		2
	ZX03705B	Pulling Rod (for 16" models)		2
	ZX03705C	Pulling Rod (for 14" models)		2
44	ZX03303	Sign Plate		1
45	ZXT45	Nail	3x8	4
60	ZXT60	Half Round Head Screw	M5 x12	10
61	ZX03721	Plate		1
62	ZX03502	Wipe Plate		2
63	ZX03503	Wipe Plate		2
64	ZX03716	Plate		1
	ZXTSA14-G	Tailstock Assy. 14" (includes # 1-13, 15-65)		
	ZXTSA16-G	Tailstock Assy. 16" (includes # 1-13, 15-65)		
	ZXTSA18-G	Tailstock Assy. 18" (includes # 1-13, 15-65)		

Steady Rest Assembly

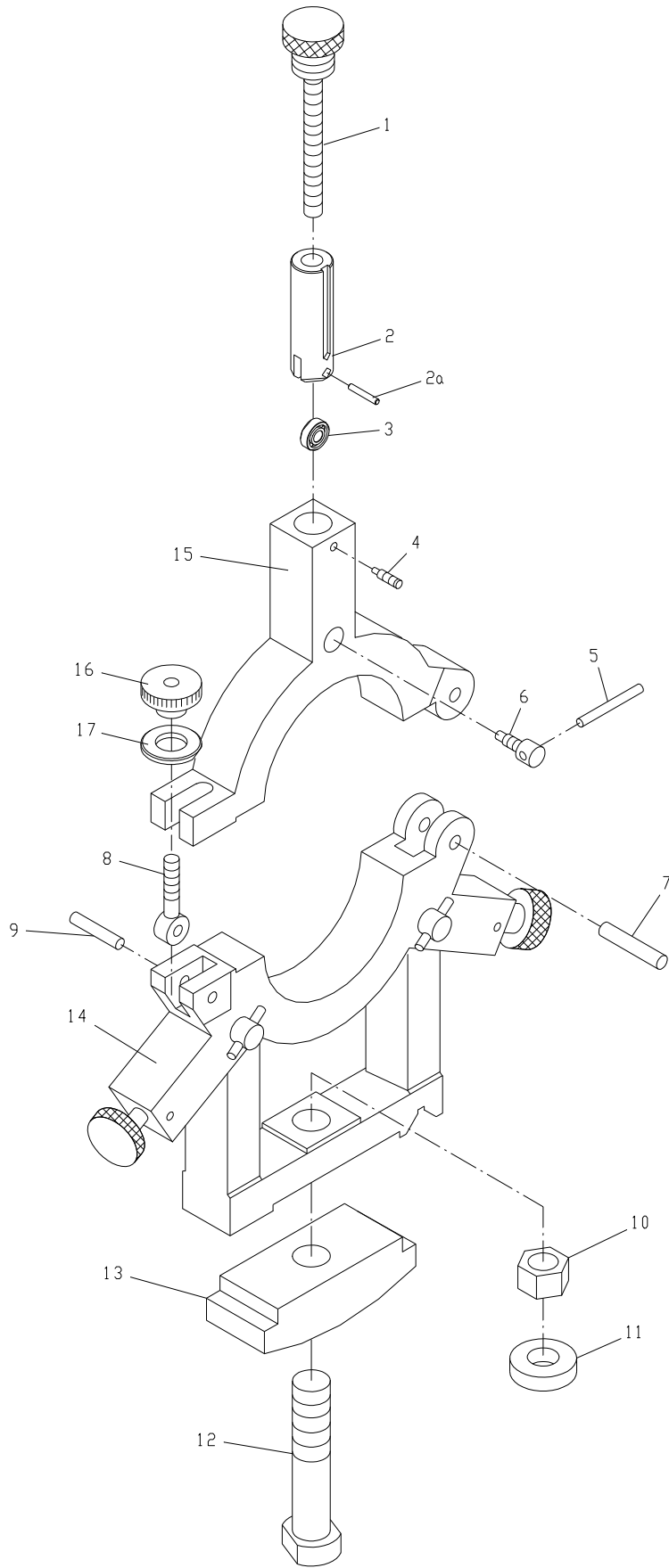

Steady Rest Assembly

Index No.	Part No.	Description	Size	Qty.
1	ZX-10702D	Screw (for 14" models)		3
	ZX-10701E	Screw (for 16" models)		3
	ZX-10701F	Screw (for 18" models)		3
2	ZX-10704G	Sliding Sleeve (for 14" models only) (serial #16081085 and higher)		
			90-180	3
	ZX-10705E	Sliding Sleeve (for 16" models only) (serial #16081085 and higher)		
			20-180	3
	ZX-10705E	Sliding Sleeve (for 18" models) (serial #16081085 and higher)		
			20-200	3
2a	GB119-8n6x24	Pin (serial #16081085 and higher)	.8n6x24	3
3	608-RS	Bearing (serial #16081085 and higher)	.8x22x7	3
4	ZX-SR04	Slotted Set Screw	M6x20	3
5	ZX-10705	Lever		3
6	ZX-10703D	Locking Screw		3
7	GB119-10n6x55	Pin	10n6x55	1
8	ZX10701	Hinge Screw		1
9	GB119-8n6x55	Pin	.8n6x55	1
10	ZX-SR10	Hex Nut	M20	1
11	ZX-SR11	Flat Washer	.20	1
12	ZX-10708	Tightening Screw		1
13	ZX-10103D-G	Clamping Plate		1
14	ZX10101D-G	Lower Part of Steady Rest (for 14" models)		1
	ZX10101E-G	Lower Part of Steady Rest (for 16" models)		1
	ZX10101F-G	Lower Part of Steady Rest (for 18" models)		1
15	ZX10102D-G	Upper Part of Steady Rest (for 14" models)		1
	ZX10102E-G	Upper Part of Steady Rest (for 16" models)		1
	ZX10102F-G	Upper Part of Steady Rest (for 18" models)		1
16	ZX-10701D	Knurling Nut		1
17	GB97.2-10	Flat Washer	10	1
	ZX-SRA14-G	Steady Rest Assembly, 14" (includes # 1-17)		
	ZX-SRA16-G	Steady Rest Assembly, 16" (includes # 1-17)		
	ZX-SRA18-G	Steady Rest Assembly, 18" (includes # 1-17)		

Follow Rest Assembly

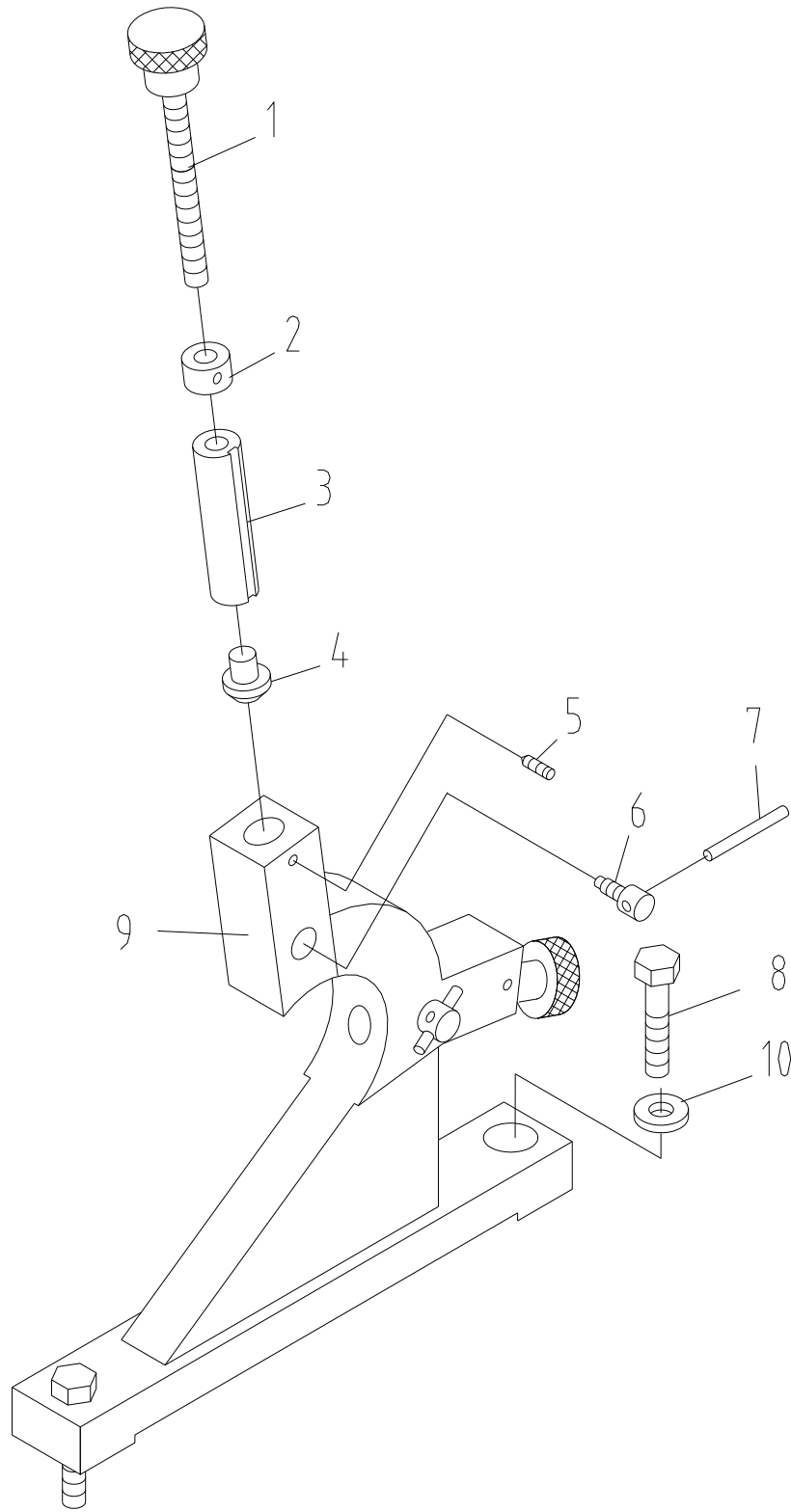

Follow Rest Assembly

Index	Part			
No.	No.	Description	Size	Qty.
1	ZX10710	Screw		2
2	ZX10704	Nut		2
3	ZX10707	Sliding Sleeve		2
4	ZX10301	Supporting Piece		2
5	ZXFR05	Slotted Set Screw	M6x10	2
6	ZX10705	Locking Screw		2
7	ZX10706	Handle		2
8	ZXFR08	Hex Cap Bolt	M12x55	2
9	ZX10102A-G	Follow Rest Casting (for 14" models)		1
	ZX10102B-G	Follow Rest Casting (for 16" models)		1
	ZX10102C-G	Follow Rest Casting (for 18" models)		1
	ZXFRA14-G	Follow Rest Assy.14" (includes # 1-7, 9)		
	ZXFRA16-G	Follow Rest Assy.16" (includes # 1-7, 9)		
	ZXFRA18-G	Follow Rest Assy.18" (includes # 1-7, 9)		
10	GB97.2	Flat Washer	12	2

Coolant & Work Light Assembly

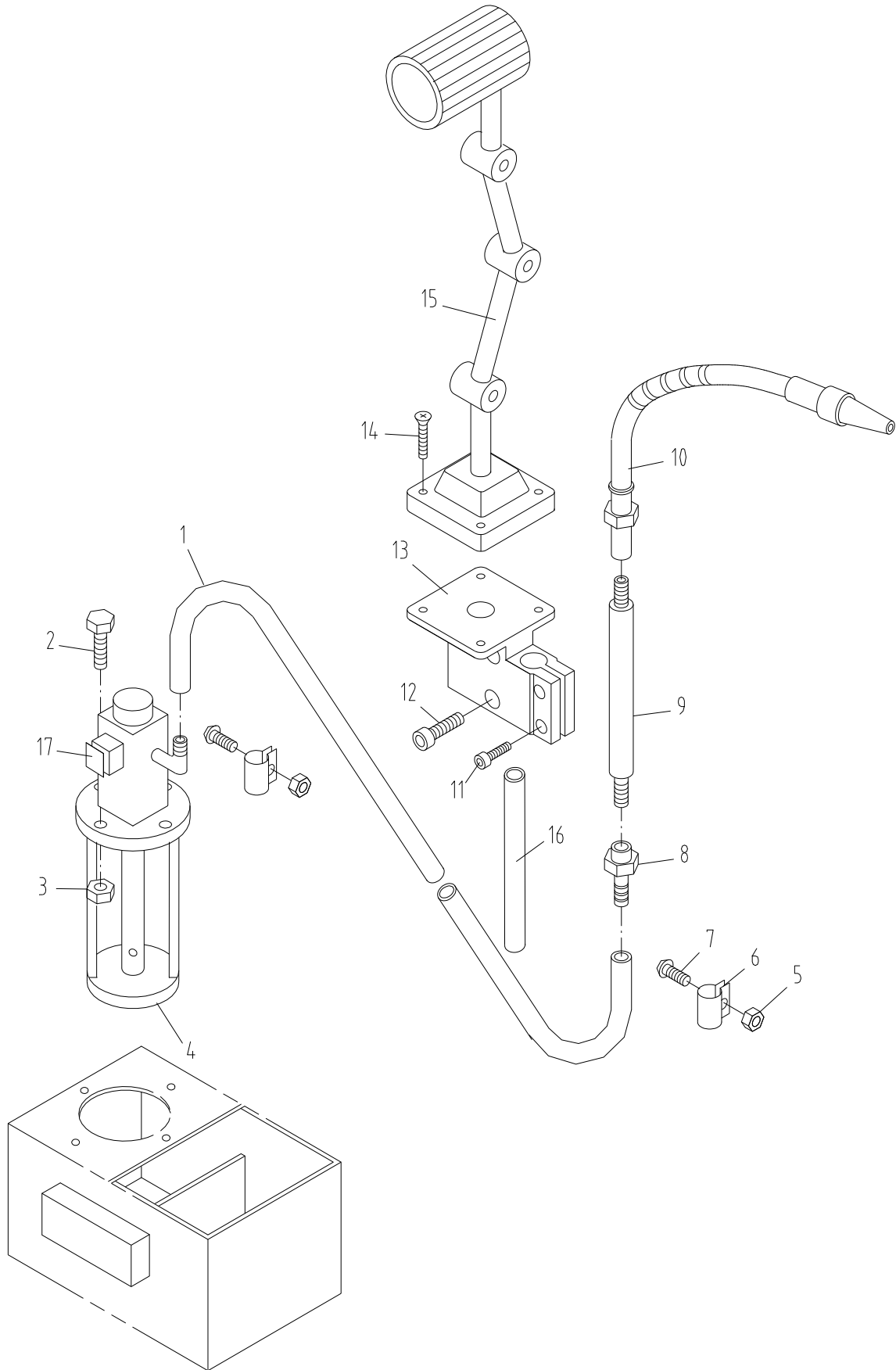

Coolant & Work Light Assembly

Index No.	Part No.	Description	Size	Qty.
1	RT001A	Rubber Tube (for 1440/1640/1840ZX)	ID 1/2"x1280mm	1
	RT001B	Rubber Tube (for 1660/1860ZX)	ID 1/2"x1780mm	1
	RT001C	Rubber Tube (for 1880ZX)	ID 1/2"x2280mm	1
2	ZXCW02	Hex Cap Bolt	M5x25	4
3	ZXCW03	Hex Nut	5	4
4	ZXCW04E	Coolant Pump		1
5	ZXCW05	Hex Nut	M6	2
6	ZX01727	Clip For Rubber Tube		2
7	ZXCW07	Half Round Head Screw	M6x16	2
8	ZX01728	Fitting		1
9	ZX01729	Flow Pipe		1
10	ZXCW10	Coolant Device		1
	ZXCW10-1	Coolant Tap	G3/8"	1
11	TS1514021	Hex Socket Cap Screw	M6x16	2
12	TS1515051	Hex Socket Cap Screw	M8x40	2
13	ZXCW13	Lamp Support		1
14	ZXS04	Cross Head Screw	M6x14	4
15	ZXCW16	Bulb (serial #16051084 and lower)	50W, AC24V	1
	ZX-EL	Machine Lamp (serial #16081085 and higher)	JC52B	1
	ZX-ELB	Bulb for led work light JC52B	3W,24V	1
16	ZX-WLCP01	Tube (for 40" models)	1.7m	1
	ZX-WLCP02	Tube (for 60" models)	2.2m	1
	ZX-WLCP03	Tube (for 80" models)	2.7m	1
17	K989	Label		1
	ZXLA	Light Assy (includes # 13-15)		

Micro Carriage Stop

Index No.	Part No.	Description	Size	Qty.
1	ZX09709E	Dial		1
2	ZXMS2	Pin	B4x8	1
3	ZX09708	Axle		1
4	ZX09105-G	Stop		1
5	ZX03302	Sign Plate		1
6	ZXMS6	Nail	3x8	2
7	ZXMS7	Hex Socket Set Screw	M6x12	1
8	ZX09106	Clamping Plate		1
9	ZXMS9	Hex Socket Cap Screw	M8x20	2

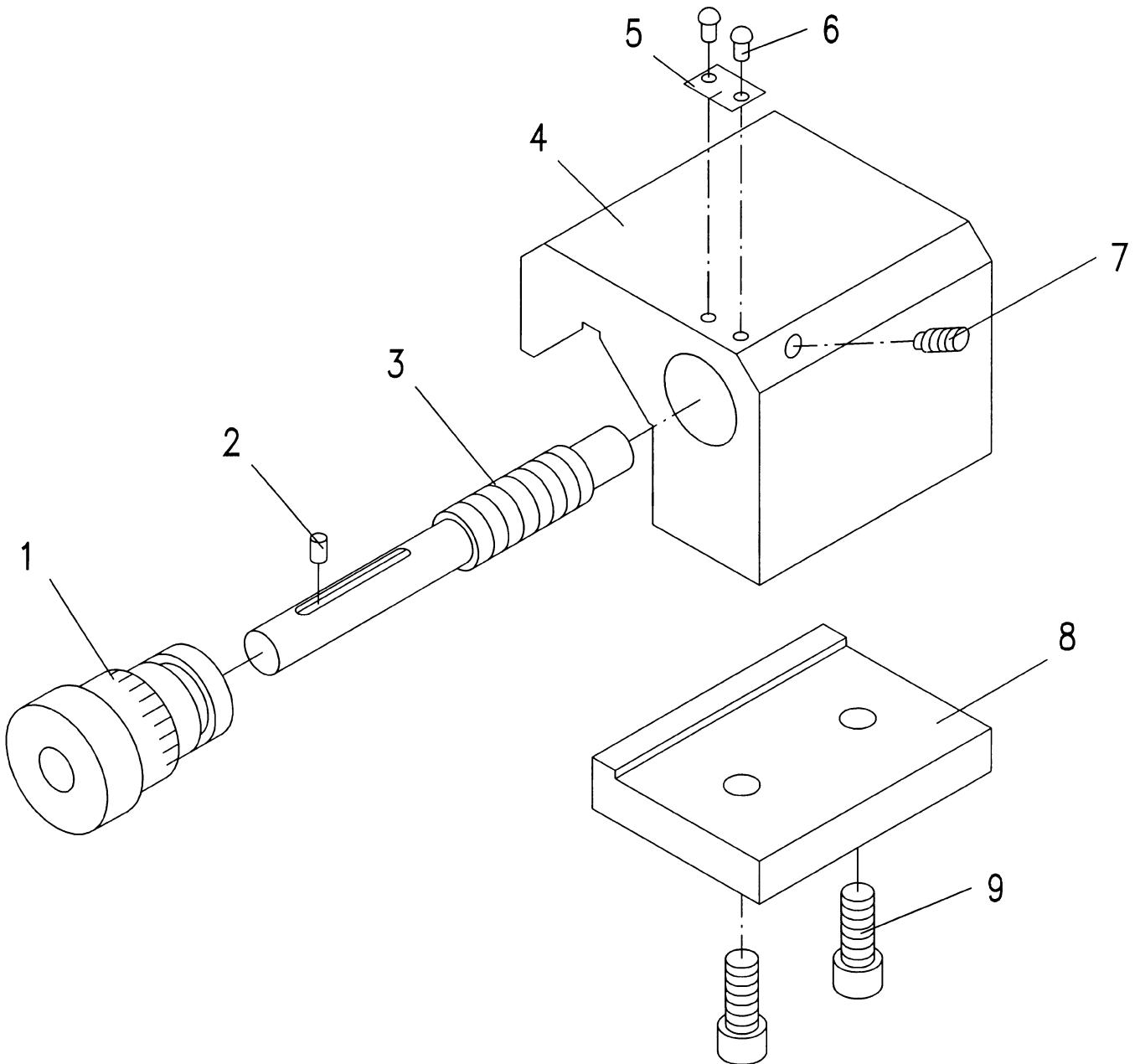

Protecting Guards For Three Rods

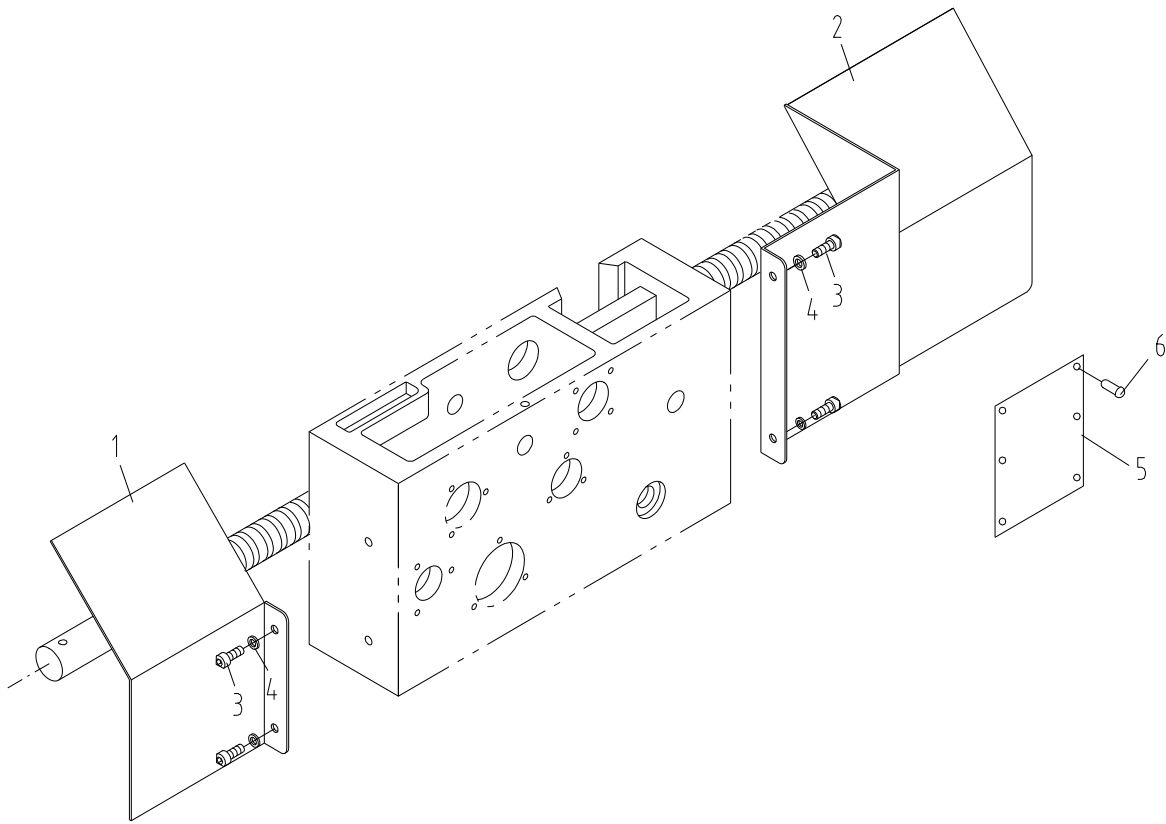

Index No.	Part No.	Description	Size	Qty.
1	ZX20701E-G	Splash Guard		1
2	ZX20702E-G	Splash Guard		1
3	ZXP03E	Hex Socket Cap Screw	M6x8	4
4	ZXP04E	Flat Washer	.6	4
5	ZX11304	Thread Chasing Label (serial #16081100 and lower)		1
	ZX11304-2	Thread Chasing Label (serial #16081101 and higher)		1
6	ZXA147	Half Round Head Screw (serial #16081100 and lower)	M3x6	6
	GB2672-M3x6	Screw (serial #16081101 and higher)	M3x6	6

(Note: This device is optional)

Safety Guard Cover

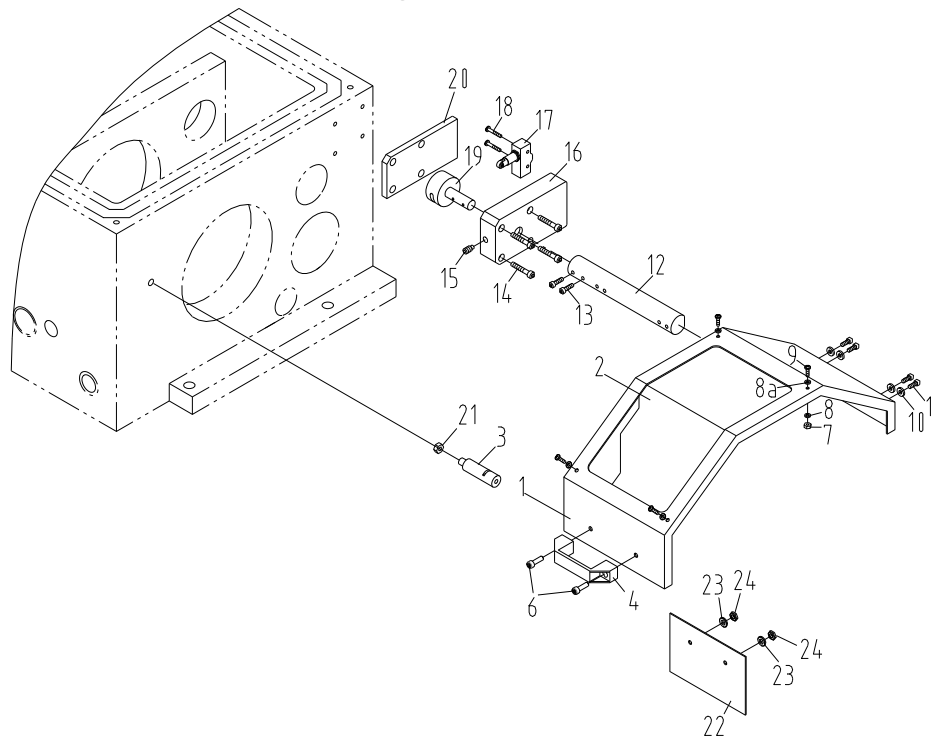

Index No.	Part No.	Description	Size	Qty.
1	ZX19701E-G	Protection Guard		1
2	ZX19501E	Protection Guard Visual Glass		1
3	ZX19704E	Fixing Rod		1
4	ZXS04E	Handle (serial #16051084 and lower)	Z96-6	1
	A=90 Black	Handle (serial #16081085 and higher)		1
6	GB70-M6x12	Hex Socket Cap Screw (serial #16081085 and higher)	M6x12	2
7	ZXS07E	Hexagon Thin Nut	M4	4
8	ZXS08E	Plain Washer	4	4
8a	GB96-4	Large Plain Washer	4	4
9	ZXS09E	Cross Recessed Pan Head Screw	M4x12	4
10	ZXS10E	Plain Washer	5	4
11	ZXS11E	Hexagon Socket Cap Head Screw	M5x16	4
12	ZX19703E	Rest Bar		1
13	ZXS13E	Slotted Set Screw	M8x10	2
14	ZXS14E	Hexagon Socket Cap Head Screw	M6x30	4
15	ZXS15E	Hexagon Socket Set Screw	M8x16	1
16	GH1440A19101E	Switch Box		1
17	ZXS17E	Stroke Switch	LXW5-11Q1	1
18	ZXS18E	Slotted Pan Head Screw	M4x25	2
19	ZX19702E	Shaft		1
20	ZX19502E	Gasket		1
21	ZXS21E	Nut	M8	1
22	GH-1640ZX19706	Board (serial # 16051084 and lower)		1
	GH-1640ZX19706B	Board (serial # 16081085 and higher)		1
23	GB97.2-6	Plain Washer	6	2
24	GB6172-M6	Hex Nut		2

(Note: This device is optional)

Parts List For Toolpost Protection Device

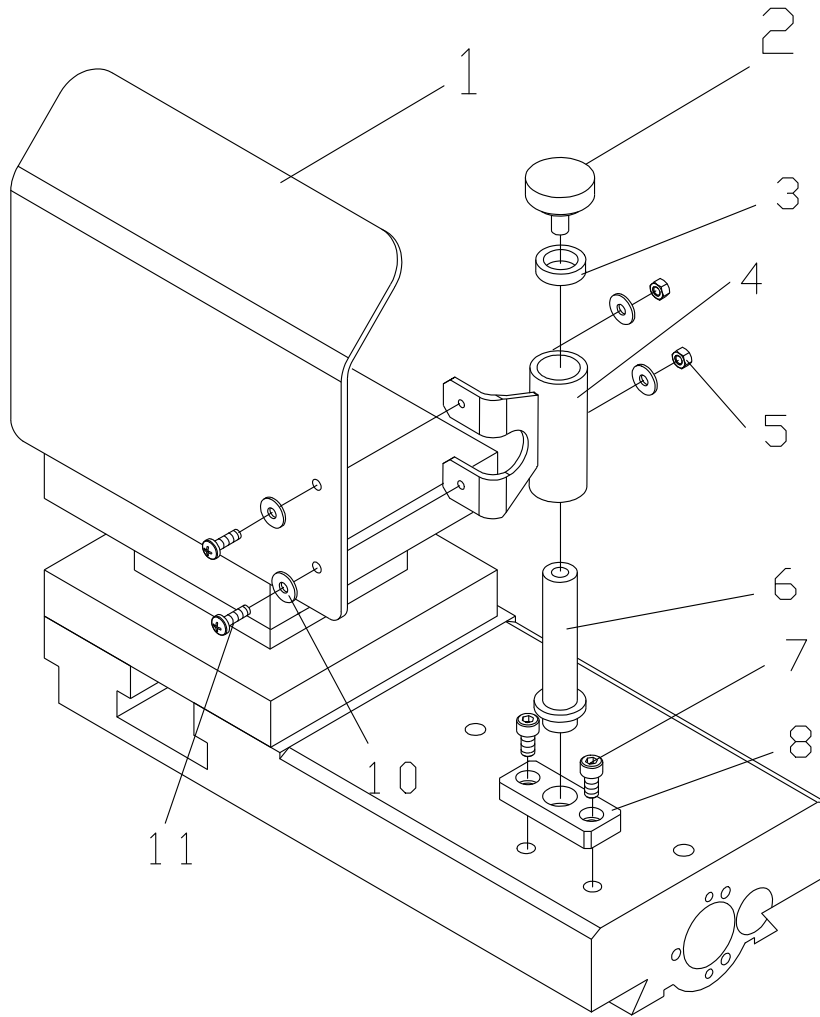

Index No.	Part No.	Description	Size	Qty.
1	GH1640ZX20501	Shield		1
2	GH1640ZX20701	Clamping Screw		1
3	GH1640ZX20703	Washer		1
4	GH1640ZX20704	Sleeve		1
5	ZXTD05	Nut	M6	2
6	GH1640ZX20705-1	Bracket		1
7	ZXTD07	Hex Socket Cap Screw	M8x16	2
8	GH1640ZX20705-2	Bracket		1
10	ZXTD10	Washer	.6	4
11	ZXTD11	Cross Recessed Pan Head Screw	M6x20	2

(Note: This device is optional)

Parts List For Lead Screw Protection Device

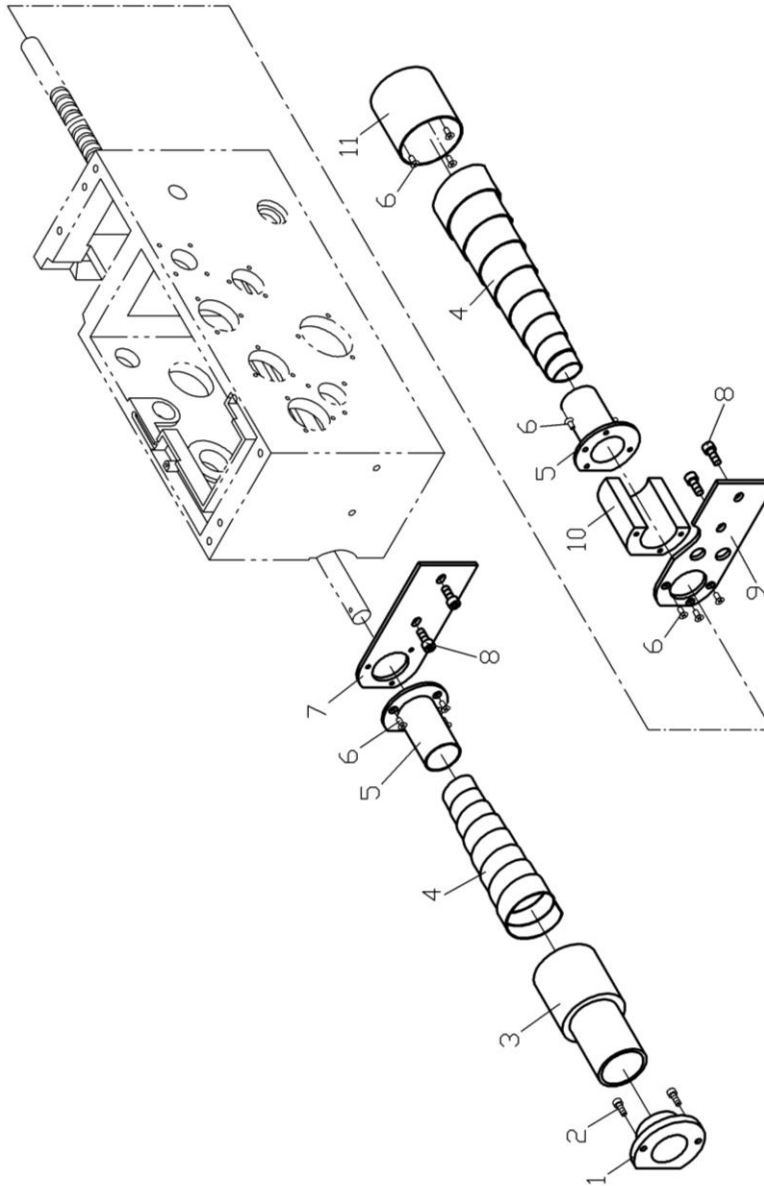

Index No.	Part No.	Description	Size	Qty.
1	1440R07101-G	Cover		1
2	ZXLD02	Cross Recessed Head Screw	M6x12	2
3	1440R07701A	Left Flange		1
4	LGB451000-75	Telescoping Sheet Cover (1000 Size)		2
	LGB451500-100	Telescoping Sheet Cover (1500 Size)		2
	LGB452000-120	Telescoping Sheet Cover (2000 Size)		2
5	1440R07702A	Flange		1
6	ZXLD06	Cross Recessed Head Screw	M5x12	10
7	1440R07703A	Left Bracket		1
8	ZXLD08	Hex Socket Cap Screw	M8x20	4
9	1440R07704A	Right Bracket		1
10	1440R07706A	Sleeve		1
11	1440R07705A	Right Flange		1

(Note: This device is optional)

Carriage Lubrication

Index No.	Part No.	Description	Size	Qty.
1	ARM	Valve Tie-in		1
2	206254	Clip Sleeve	CS-6	2
3	206252	Vitta Tie-in	CB-6	2
4	CL-04	Nylon Pipe	Φ6	0.4m
5	CL-05	Spring Sleeve	Φ6	0.2m
5a	PC-4-1	Nip	Φ4	3
5b	GB70- M5×10	Hex Socket Cap Screw	M5×10	3
6	106095	Tie-in	SA-4-6	1
7	CL-07	Tie-in	KC-4	4
8	CL-08	Nylon Pipe	Φ4	0.7m
9	CL-09	Spring Sleeve	Φ4	0.7m
10	106252	Vitta Tie-in	CB-4	4
11	106254	Clip Sleeve	CS-4	4
12	106255	Plug	CP-4	1
13	106411	Connector	PJ-6D	1
14	GB70 M5×20	Hex Socket Cap Screw	M5×20	2

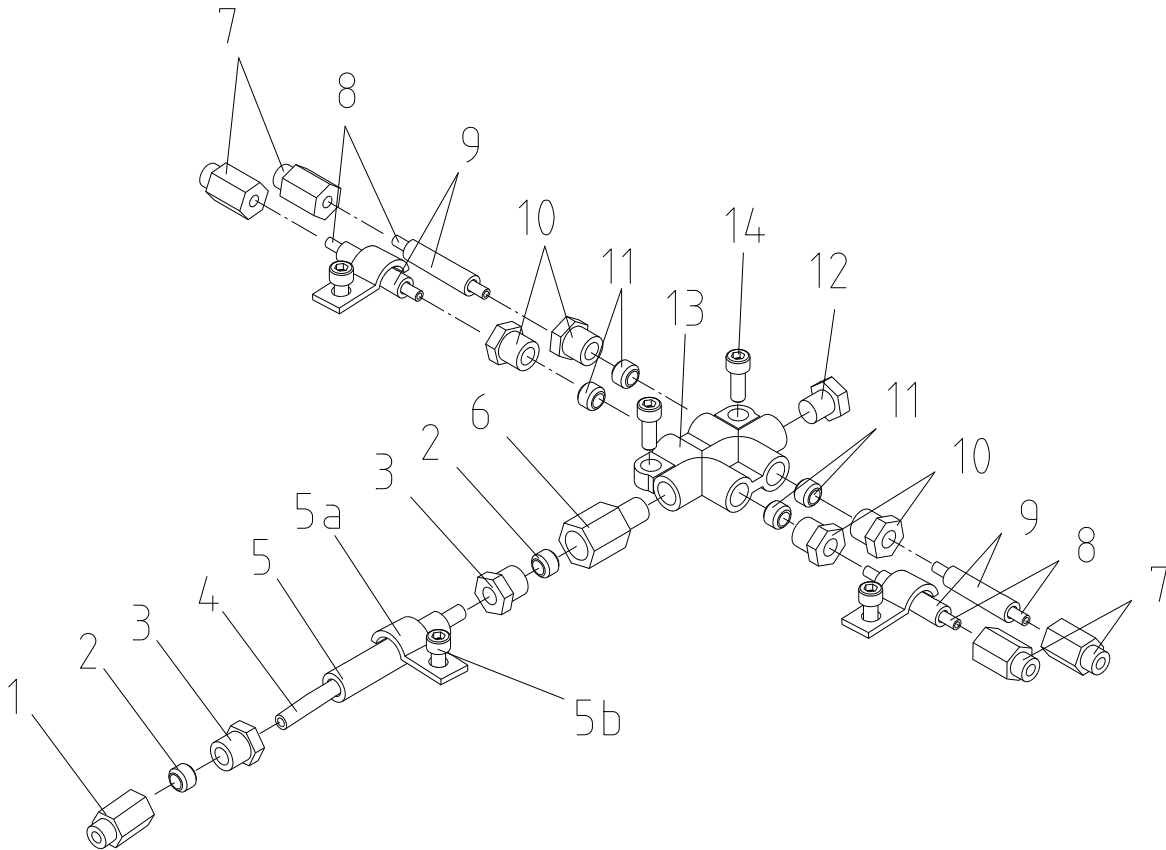

(Note: This device is installed from serial #14041007)

Other Parts

Index	Part			
No.	No.	Description	Size	Qty.
1A.....	ZXOP-1A.....	3-Jaw Chuck (mounted on lathe).....	.250, D1-8.....	1
1B.....	ZXOP-1B.....	Chuck Wrench		1
2A.....	ZXOP-2A.....	4-Jaw Chuck.....	.320, D1-8.....	1
2B.....	ZXOP-2B.....	Chuck Wrench		1
3.....	ZXOP-03.....	300mm Face Plate(for 14"/16"models).....		1
	ZXOP-03N.....	400mm Face Plate(for 18"/22"models).....		1
4.....	ZXOP-04.....	Tool Tightening Wrench		1
5.....	ZXOP-05.....	Cam Tightening Wrench		1
6.....	ZXOP-06.....	Center		1
7.....	ZXOP-07N.....	MT-5 Live Center		1
8.....	ZXOP-08.....	Morse Reduction Sleeve		1
9.....	ZXOP-09.....	Oil Gun.....		1
11.....	ZXOP-11.....	Gap Bridge Pin Driver.....		1
12.....	ZXOP-12.....	Hex Wrench2, 2.5, 3, 4, 5, 6, 8, 10.....	8
13.....	ZXOP-13.....	Double End.....		1
14.....	ZX-10704G.....	Sliding Sleeve (for14" models only).....		3
15.....	ZXOP-14.....	Flat Blade Screw Driver.....		1
	ZXOP-15.....	Cross Point Screw Driver		1
16.....	ZXOP-16.....	Adjustable Wrench.....		1
17.....	ZXOP-17.....	Round Nut Wrench		1
18.....	ZXOP-18.....	Shear Pin.....		2
21.....	ZXOP-21.....	Indicate Bulb.....	.110V or 24V.....	1
22.....	ZXOP-22.....	Taper Piece.....		1
23.....	TNMP08501A.....	Gear (for 14"/16" models).....	.3.5m35T.....	1
	TNMP08501B.....	Gear (for 18" models).....	.4m35T.....	1
24.....	DTH-120.....	Pads (serial #19011204 and higher).....		6
24a.....	M16×115.....	Bolts (serial #19011204 and higher).....		3
24b.....	M16×160.....	Bolts (serial #19011204 and higher).....		3
25.....	GB5782-M12x40.....	Hex Head Cap Screw	M12x40.....	2
	GB97.2-12.....	Flat Washer.....	.12.....	2

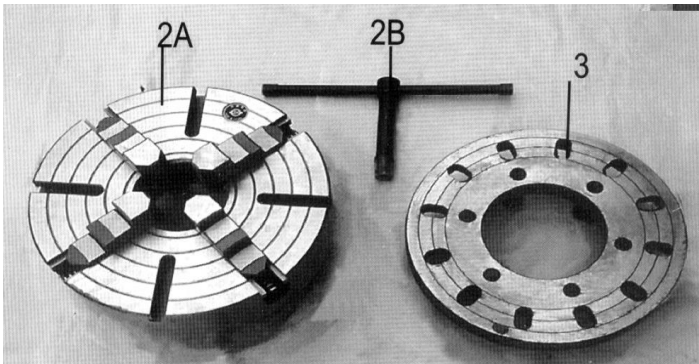

Electrical Components

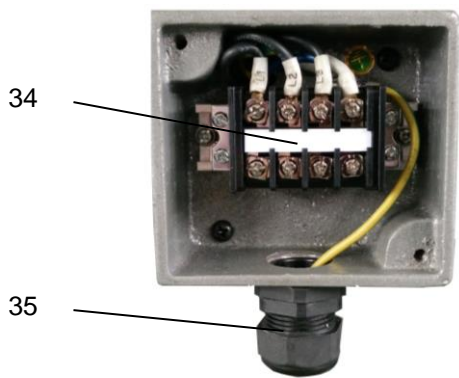
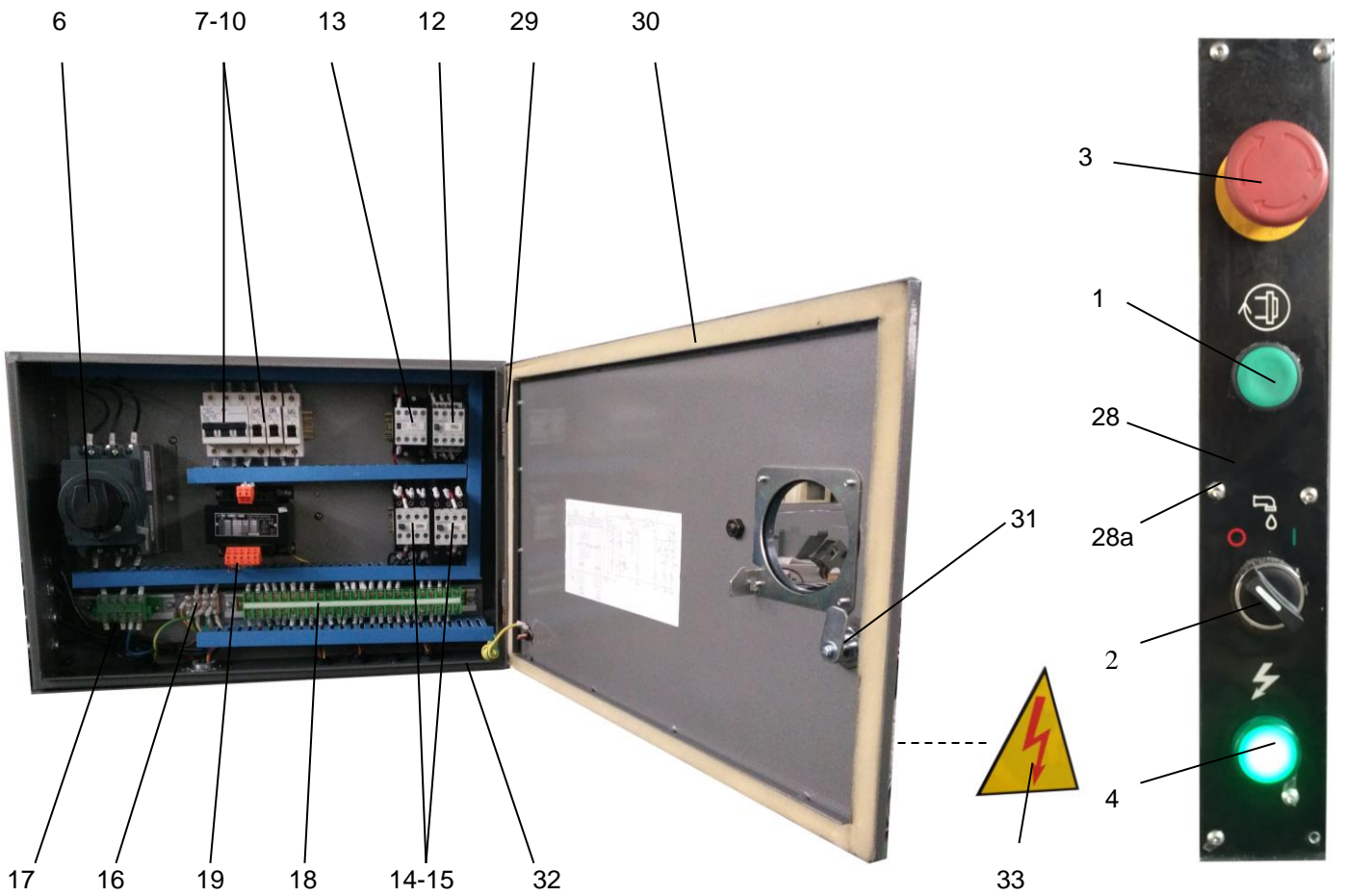

Electric Cabinet

Index No.	Part No.	Description	Size	Qty.
1	ZX-SB1E	Jog Button	XB7-EA1C	1
2	ZX-SA2E	Coolant Control Button	ZB2-BE101C	1
3	ZX-SB2ESB3E	Emergency Stop	ZB2-BE102C	2
4	ZX-HLE	Power Indicator Light	XB7-EVF3LC	1
5	SQ2SQ3E	Stroke Switch (not shown)	TM1306	2
6	ZX-QF	Breaker (40A) (serial # 16051084 and lower)	DZ15-40	1
	ZX-QF	Breaker (40A) (serial # 16081085 and higher)	NSC100B	1
7	ZX-FU1	Breaker (3A) (serial # 16051084 and lower)		1
	ZX-QF1	Breaker (3A) (serial # 16081085 and higher)	DZ47-63	1
8	ZX-FU2	Breaker (3A) (serial # 16051084 and lower)		1
	ZX-QF2	Breaker (3A) (serial # 16081085 and higher)	DZ47-63	1
9	ZX-FU3	Breaker (3A) (serial # 16051084 and lower)		1
	ZX-QF3	Breaker (3A) (serial # 16081085 and higher)	DZ47-63	1
10	ZX-FU5	Breaker (3A) (serial # 16051084 and lower)		1
	ZX-QF4	Breaker (3A) (serial # 16081085 and higher)	DZ47-63	1
11	ZX-QE	Temperature Relay (not shown)	JW6	1
12	ZX-KM2E	A.C. Contactor	3TB40	1
13	ZX-KAE	A.C. Contactor	3TH80	1
14	ZX-KM3E	A.C. Contactor	3TB43	1
15	ZX-KM4E	A.C. Contactor	3TB43	1
16	ZX-XBE	Copper Plate (for grounding)		1
17	ZX-XT1E	Wiring Board	JTL-25	1
18	ZX-XT2E	Wiring Board	JF25	1
19	ZX-TCE	Control Transformer	JBK5-160VATH	1
20	ZX-SQ1E	Stroke Switch (not shown)	JW2A-11H/W1	1
21	SQ4E	Stroke Switch (not shown)	LXW5-11Q	1
22	SQ5E	Stroke Switch (not shown)	QKS8	1
28	ZX18301G	Operation Plate (serial # 16081101 and higher)		1
28a	GB2672-M4x8	Screw (serial # 16081101 and higher)	M4x8	7
29	C6140W18705	Small Shaft		2
	C6140W18706	Pin Shaft		2
	GB6170-M8	Hex Nut	M8	2
30	ZX18703/9-G	Electric Box Door		1
31	MS-705	Lock		1
32	ZX18703-G	Electric Box		1
33	GHB1340A18508-6	Warning Label		1
34	AZ1-2004	Wiring Board		1
	GB818-M4x6	Cross Recessed Pan Head Screw	M4x6	2
	GB97.2-4	Flat Washer	4	2
35	PG13.5-M20x1.5	Sheathed Wire Head	M20x1.5	1

Wiring Diagram

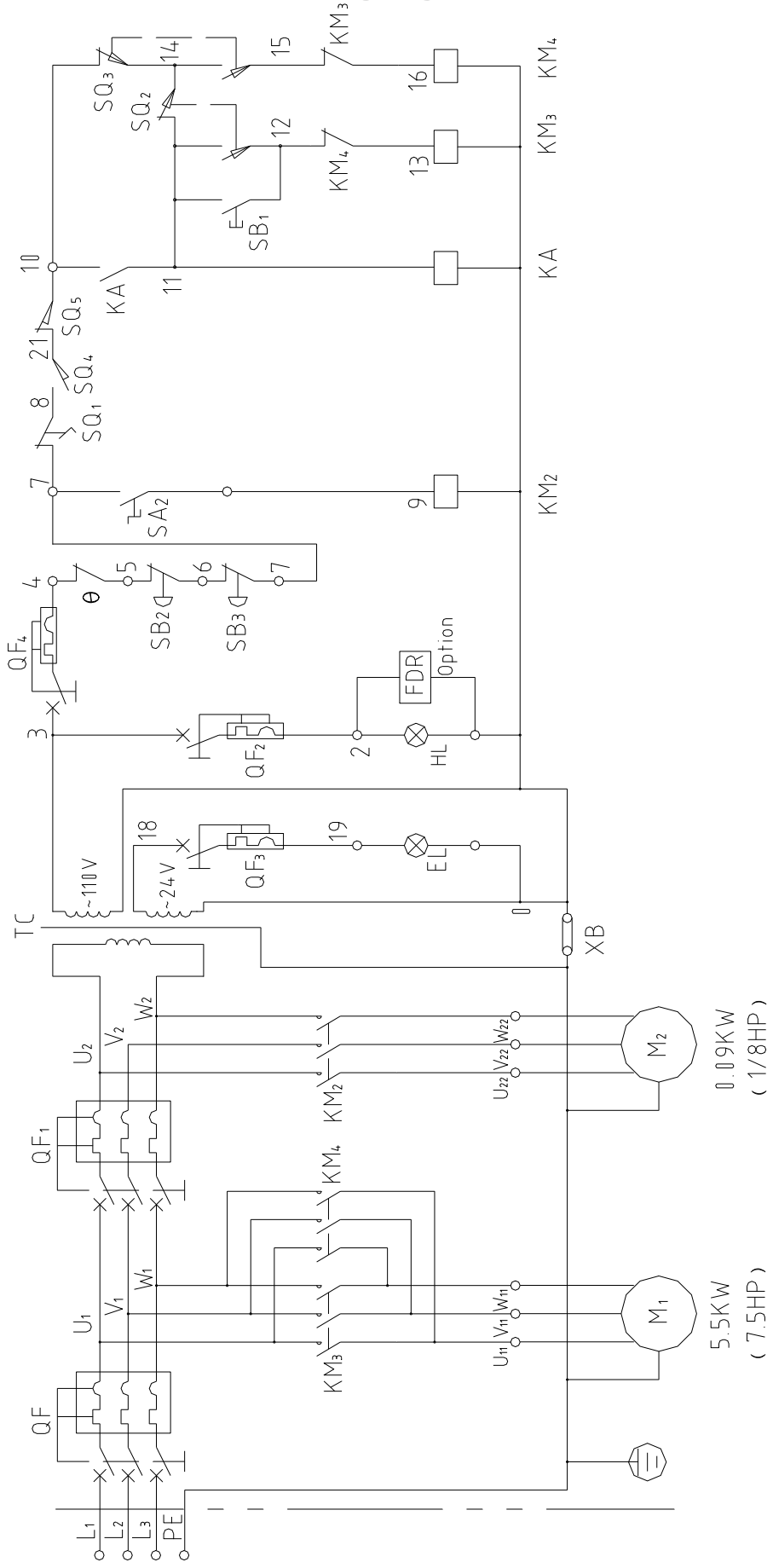

Flexible Stainless Wire Woven Tube

1 ZX-WLCP01 Flexible Stainless Wire Woven Tube for Protecting Work Light Cable(for 1640/1840ZX)	
	 M20×1.5M20×1.5-1.7m 1
2 ZX-WLCP02 Flexible Stainless Wire Woven Tube for Protecting Work Button(for 1640/1840ZX) 1
	 M16×1.5M16×1.5-1.6m 1
3 ZX-WLCP03 Flexible Stainless Wire Woven Tube for Protecting Work Light Cable(for 1860ZX) 1
	 M20×1.5M20×1.5-2.3m 1
4 ZX-WLCP04 Flexible Stainless Wire Woven Tube for Protecting Work Button(for 1860ZX) 1
	 M16×1.5M16×1.5-2.3m 1
5 ZX-WLCP05 Flexible Stainless Wire Woven Tube for Protecting Work Light Cable(for 1880ZX) 1
	 M20×1.5M20×1.5-2.7m 1
6 ZX-WLCP06 Flexible Stainless Wire Woven Tube for Protecting Work Button(for 1880ZX) 1
	 M16×1.5M16×1.5-2.7m 1
7 ZX-DDCP01 Flexible Stainless Wire Woven Tube for Protecting DRO Cable (for 1640/1840ZX with DRO) 1
	 M20×1.5-2.3m 1
8 ZX-DDCP02 Flexible Stainless Wire Woven Tube for Protecting DRO Cable (for 1860ZX with DRO) 1
	 M20×1.5-2.7m 1
9 ZX-DDCP03 Flexible Stainless Wire Woven Tube for Protecting DRO Cable (for 1880ZX with DRO) 1
	 M20×1.5-3.3m 1
10 ZX-TPCG Flexible Stainless Wire Woven Tube for Protecting Chuck Guard Cable 1
	 M16×1.5M16×1.5-0.8m 1
11 ZX-TPRFS Flexible Stainless Wire Woven Tube for Protecting Rapid Feed System Wires (for 1860/1880ZX) 2
	 M24×1.5M24×1.5-2.5m 2

