



GHD-55PFAL

DRILLING MACHINE

Original:
GB
Operating Instructions



JPW Tool Group Hong Kong Limited

98 Granville Road, Tsimshatsui East, Kowloon, Hong Kong, PRC
www.jettools.com

Импортер в РФ: ООО «ИТА Технолджи»

105082, Москва, Переведеновский пер., д. 17
www.jettools.ru

Made in PRC / Сделано в КНР

2024-09

General safety notes

Milling machines can be dangerous if not used properly. Therefore the appropriate general technical rules as well as the following notes must be observed.



Read and understand the entire instruction manual before attempting assembly or operation.



Keep this operating instruction close by the machine, protected from dirt and humidity, and pass it over to the new owner if you part with the tool.

No changes to the machine maybe made.

Daily inspect the function and existence of the safety appliances before you start the machine.

Do not attempt operation in this case, protect the machine by unplugging the mains cable.

Do not wear gloves while operating this machine.

Remove all loose clothing and confine long hair.



Before operation the machine, remove tie, rings, watches, other jewelry, and roll up sleeves above the elbows.

Wear safety shoes; never wear leisure shoes or sandals.

Always wear the approved working outfit:

- Safety goggles
- Ear protection
- Dust protection



Install the machines so that there is sufficient space for safe operation and workpiece handling.

Keep work area well lighted.

The machine is designed to operate in closed rooms and must be placed stable on firm and levelled table surface.

Make sure that the power cord does not impede work and cause people to trip.

Keep the floor around the machine clean and free of scrap material, oil and grease.

Stay alert!

Give your work undivided attention.

Use common sense. Do not operate the machine when you are tired.

Keep an ergonomic body position.

Maintain a balanced stance at all times.

Do not operate the machine under the influence of drugs, alcohol or any medication. Be aware that medication can change your behavior.



Never reach into the machine while it is operating or running down.



Never leave a running machine unattended. Before you leave the workplace switch off the machine.

Keep children and visitors a safe distance from the work area.

Do not operate the electric tool near inflammable liquids or gases.

Observe the fire fighting and fire alert options, for example the fire extinguisher operation and place.

Do not use the machine in a damp environment and do not expose it to rain.

Metal dust is explosive and can also represent a risk to health.

Dust from some tropical woods in particular, and from hardwoods like beach and oak, is classified as a carcinogenic substance.

Always use a suitable dust collection device.

Before machining, remove any nails and other foreign bodies from the workpiece.

Make sure to guide and hold the chisel with both hands safe and tight during machining.

Work only with well sharpen tools.

Machine only stock which is chucked

securely on the machine, always check before switching the machine on.

Provide workpieces with center holes before clamping between centers.

Work large and unbalanced workpieces at low spindle speed only. Workpieces with cracks may not be used.

Remove the chuck key or dowel pins before turning the machine on.

Always close the belt cover.

Specifications regarding the maximum or minimum size of the workpiece must be observed.

Test each set-up by revolving the work by hand to insure it clears the tool rest and bed. Check setup at the lowest speed before you increase to the operating speed.

Do not remove chips and workpiece parts until the machine is at a standstill.

Never stop workpiece with the hand during run out.

Do not attempt to engage the spindle lock pin until the spindle has stopped.

Never take measurement on a rotating workpiece.

Do not stand on the machine.

Connection and repair work on the electrical installation maybe carried out by a qualified electrician only.



Have a damaged or worm power cord replaced immediately.

Make all machine adjustments or maintenance with the machine unplugged from the power source.



Vertical Drilling Machine

Model: GHD-55PFAL

Operation Manual

Max. Drilling Diameter: 50mm

Series Number:

Contents

- 1. Main use and features of the machine**
- 2. Main technical data**
- 3. Brief description of the driving system and its structure**
- 4. Electrical system**
- 5. Lubrication and coolant system**
- 6. Hoisting and installation**
- 7. Use and operation of the machine**
- 8. Machine adjustment**
- 9. Machine use and maintenance**
- 10. Machine accessories**

Dear end-user,

Thank you very much for choosing our products. Please let us have the model of your machine, series number, as well as the name, address and correspondence method of your company in order to facilitate us to let you have a good service.

Important notice:

1. Please immediately contact your dealer in case the machine, accessories or documents are not in conformity with those indicated in the packing list after the machine package is opened.
2. Please carefully read this Operation Manual particularly the electric part of this documents before installation, testing and running the machine.
3. Removing grease on the machine (particularly on the column) and checking lubrication oil in each place is well filled . Running the machine without lubrication oil is strictly forbidden. Lubrication of the machine as per the stipulation of this documents is required.
4. Ground wire of the machine shall be well connected. When test running, push jog button in slow spindle speed to check if direction of spindle revolution is correct.
5. Machine must be stopped if spindle speed or feed rate change is necessary.
6. Please check if cutting tool or work piece is well clamped before machining
7. The red mushroom push button located in front of the spindle box is an emergence push button for emergency purpose only. Familiar with its position and its use are necessary.
8. Professional electric service engineer is required for electric maintenance.
9. The machine must be stopped when you need removing away the cutting material around the drill. Moving the cutting material by hand or by hook is definitely forbidden.
10. Correct use and daily maintenance of the machine are required in order to keep machine accuracy and its lifetime in long time.
11. We will much appreciate if you could solve some problems of the machine.
In order to facilitate us for the service, please let us know the details regarding the places and phenomenon of the troubles if you could not solve problems.

1. Main use and features of the machine:

GHD series vertical drilling machines are our new products designed and developed by our-self based on our accumulated experience in so many years in this field. It is a light, column type, superior quality and high efficiency machine with milling function vertical drilling machine. It is really a multi-function universal machine which could be widely used for small and middle sizes of work pieces for drilling, spot facing, reaming, tapping and milling etc. Besides, some machine tool accessories could also be used on this machine. The machines are suitable for the machining workshop, maintenance workshop and production line etc.

Features:

- 1.1 Good in appearance, easy in operation, convenience in maintenance and well consideration in safety protection
- 1.2 Single speed motor is to be used for the main drive system with sufficient driving power but saving energy. Wide spindle speed range is adopted driven by gears.
- 1.3 Oil lubrication both for the main driving system and for the feed driving system could be supplied automatically by a new type of trochoid pump when it is working in forward and reverse revolution.
- 1.4 The spindle features good rigidity and good wear resisting and equipped with tool disassembly and balancing device.
- 1.5 The worktable could be turned round the column center line or worktable center line itself or horizontal shaft centerline by manual and could be moving up and down by manual or automatically.
- 1.6 A locking device for the spindle quill is available for the purpose of milling job. There is a screw hole located at the end of the main spindle for the clamping of different kinds of milling cutters.
- 1.7 Main operation levers and push buttons could be reached easily that makes you comfortable when you operate the machine.
- 1.8 Spindle feed both in mechanical and in electrical with micro feed structure is available in this series machines.
- 1.9 Besides the normal indication both for the spindle speed and for the cutting depth, the machine also has a digital display showing the above figures.

1.10 Superior quality material with special treatment for the wear-resisting purpose has been used for transmission parts such as gears, worm and worm shaft, rack, lead screw etc as well as for some key parts like spindle and spindle quill.

1.11 An adjustable safety protection clutch in the spindle feed device is available in order to prevent the machine and tools from damage when overloaded.

1.12 A safety protection guard under the spindle box is available as it is not only prevent coolant splash while cutting but also could observe the machining status.

The guard is interlocked with the spindle, so when the guard is opened, the spindle could not be running until the protection guard keeps his position.

2. Main technical data:

2.1 Main technical data

No.	Name of the items	Unit	Data
1	Max. drilling diameter (steel)	mm	50
2	Max. tapping diameter (steel)	mm	M30
3	Max. milling cutter diameter	mm	80
4	Distance between spindle center line to the center line of column	mm	360
5	Max. distance between spindle end to the surface of the worktable (automatic)	mm	585(410)
6	Max. distance between spindle end to the worktable surface of the base	mm	1170
7	Max. stroke of the spindle	mm	240
8	Spindle taper	Morse	MT4
9	Number of speed steps of the spindle	Step	12
10	Spindle speed range	r/min	77~2060
11	Feed steps of the spindle	Step	4
12	Feed range of the spindle	mm/r	0.1-0.4
13	Max. stroke of worktable and its bracket	Mm	530(410)
14	Rotation degree of worktable and its bracket in cross direction	degree	±45°
15	Working area of the worktable (L x W)	mm	570×480
16	Working area of the worktable of the base (L x W)	mm	445×435
17	Numbers and width of the T slots both for worktable and worktable of base	mm	3-T14, 2-T18
18	Diameter of column	mm	φ 180
20	Power and speed of the main motor	kW, rpm	3/1440
21	Power and speed of the worktable up and down motor.	kW, rpm	0.25/1440
22	Power and flow rate of the coolant pump motor	kW, L/min	0.18 / 20
23	Machine dimension (L x W x H)	mm	950×680×2405
24	Weight of the machine (Net weight/Gross weight)	kg	670/730

2.2 For the machine appearance and its main technical data, see diagram 1.

3. Brief description of the driving system and its structure:

The machine consists of spindle box, column, machine base, worktable and its bracket, electric cabinet, coolant device and machine accessories, total seven component parts. Spindle revolution is main motion of the machine. During drilling and milling processing, spindle movement along with its axis is a feed motion, during milling operation, movement of worktable in longitudinal or cross directions or rotation of the worktable is also a feed motion. Worktable up and down movement and worktable turn round itself is an auxiliary motion. To those big or higher work piece that could be clamped on the worktable of the base. The worktable and its bracket should turn round the column to a proper area far away from the machining area.

Two separately vertical motors realize machine transmission. A special pump supplies coolant water.

Two operating levers in the front of spindle box could make changes for the spindle speed in 12 steps. Changing either lever position could drive a triple gear and a quadruple gear moving along with axis direction results the speed change. One of levers has an idle position that is for the spindle rotation by manual for loading and unloading of tool cutters as well as for the adjustment of work piece only. Adjustment of the feed rate could be realized by shifting a set of gears controlled by changing a lever position in the right corner of spindle box. It also has an idle position for disengaging power feed transmission of the spindle for the micro adjustment of the spindle by manual.

Up and down movement of the worktable and its bracket is completed by a vertical speed reduction motor. Of cause, little adjustment for the height of the worktable could also be made by manual.

Two kinds of lubrication, auto or manual, of the machine are available. Auto lubrication system consists of a filter (located inside of a tank under spindle box), a lubrication oil pump and an oil distributor (located on the top of spindle box), a visual window and an oil nozzle etc.

Please refer to the diagram 2 for the transmission system of the machine.

For the gear, worm and worm shaft, rack and pinion etc, please see table 1.

For the details of roller bears to be used on the machine, please refer to the diagram 3 and for a list of roller bears, please refer to the table 2.

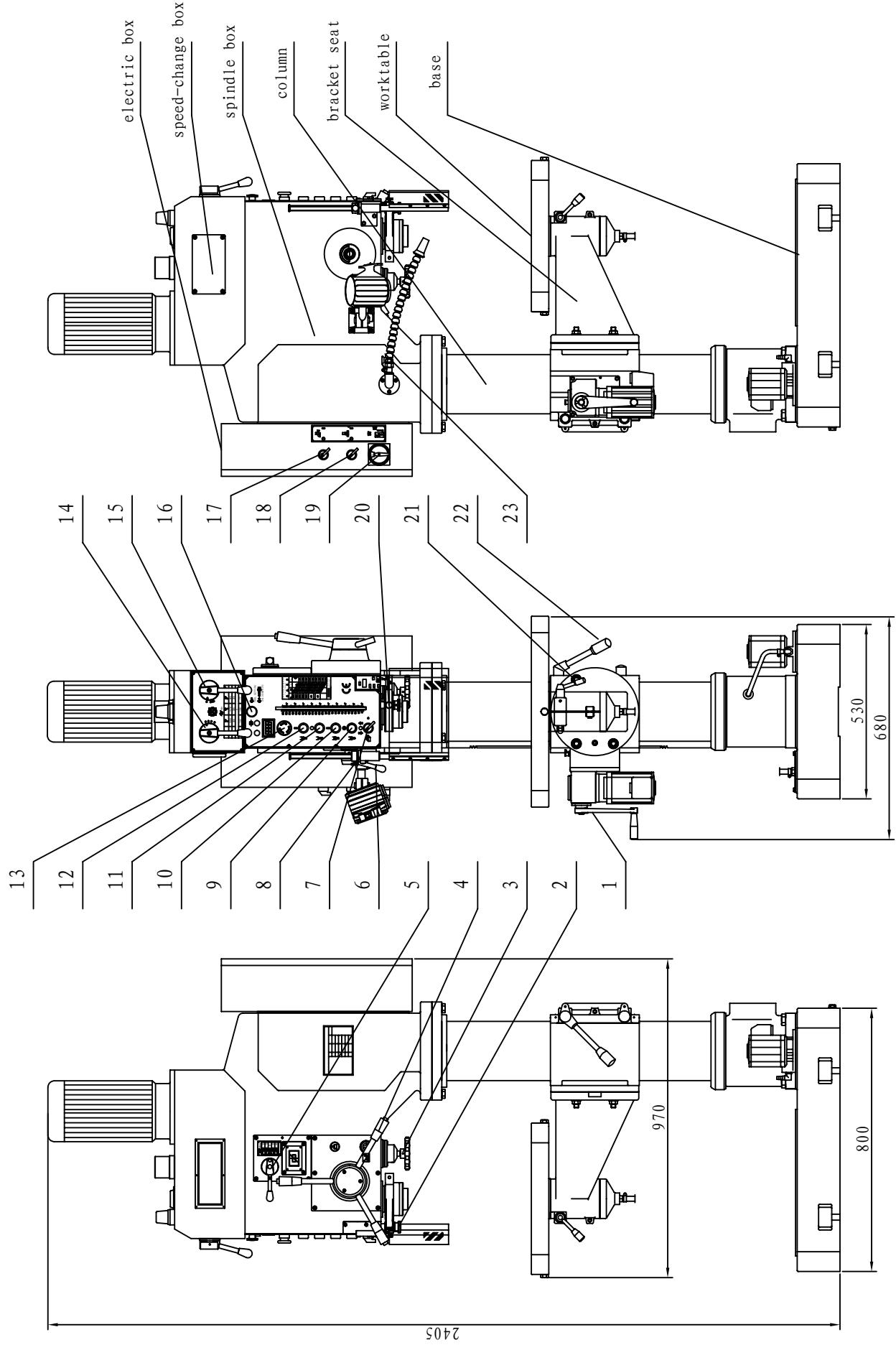

drawing (1) picture of appearance of machine

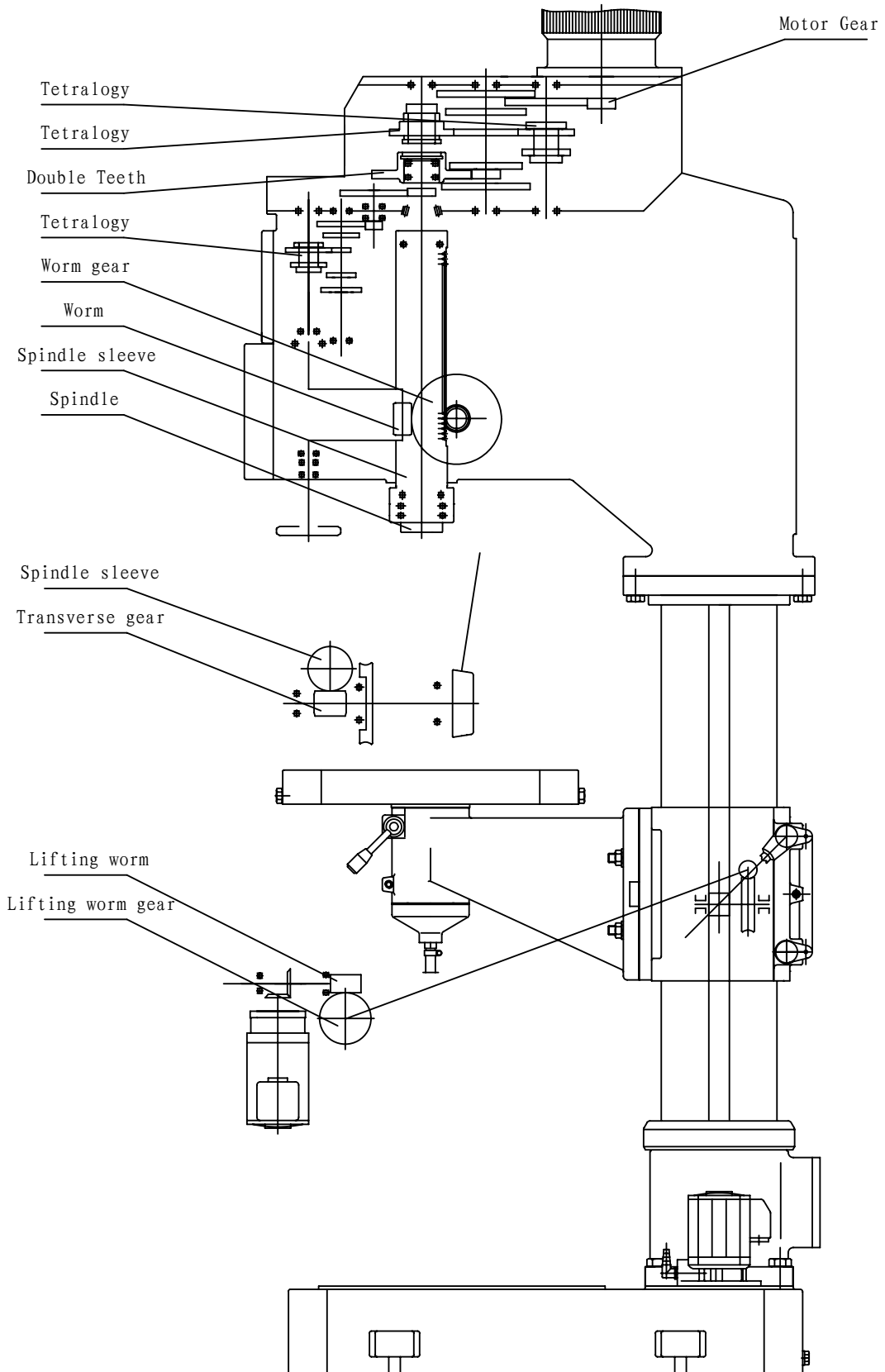

drawing 2 picture of transmission

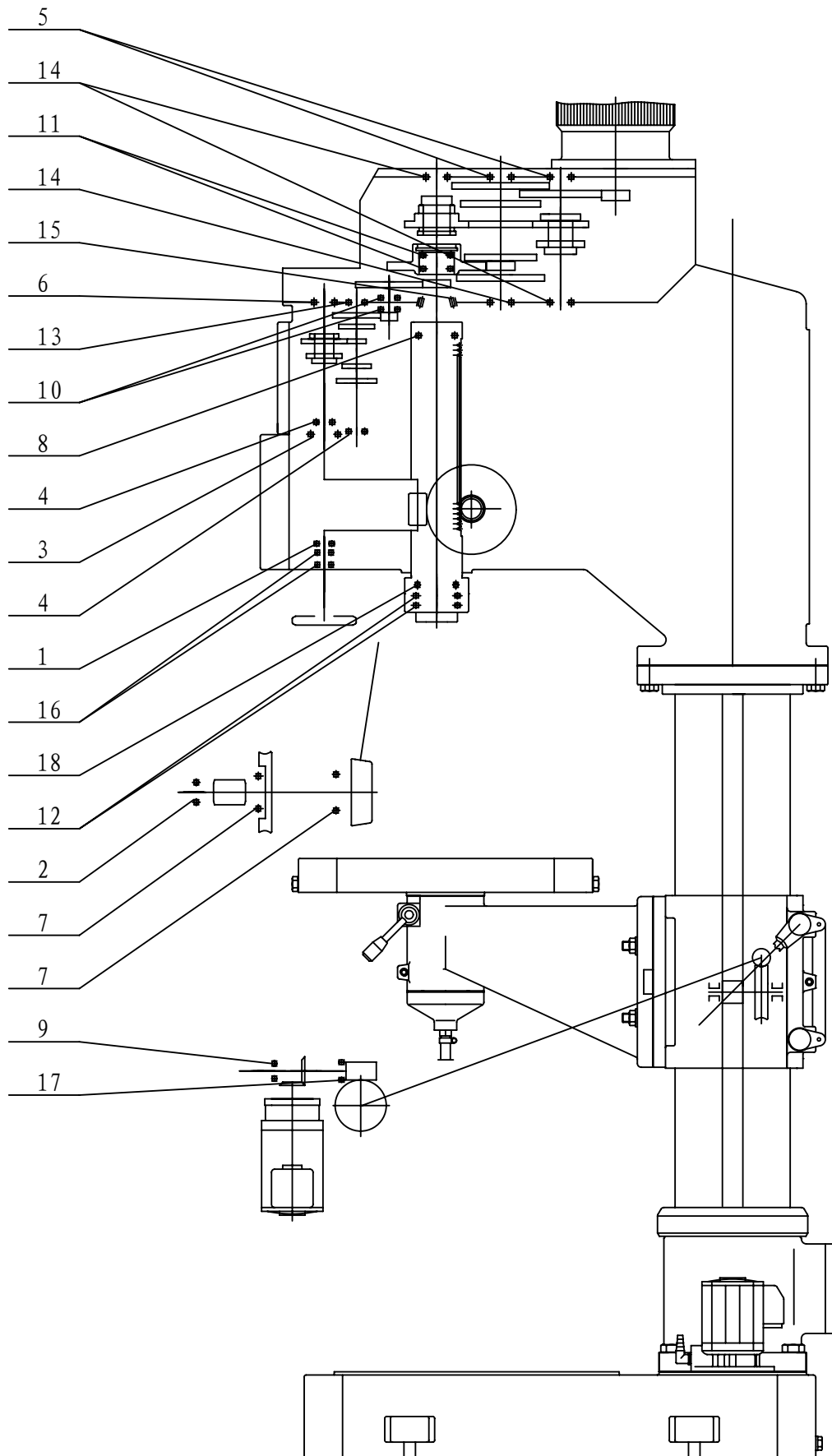

drawing 2 picture of rolling bearing

Roller bearing table

Table (2)

No.	Model	Name	Specification	Q'ty	Accuracy
1	GB276,102	Deep racing ball bearing	12×35×8	1	
2	GB276,104	Deep racing ball bearing	20×42×12	1	
3	GB276,106	Deep racing ball bearing	30×55×13	1	
4	GB276,202	Deep racing ball bearing	15×35×11	2	
5	GB276,204	Deep racing ball bearing	20×47×14	2	
6	GB276,303	Deep racing ball bearing	17×47×14	1	
7	GB276,1000909	Deep racing ball bearing	45×68×12	2	
8	GB276,D1000909	Deep racing ball bearing	45×68×12	1	D
9	GB276,7000102	Deep racing ball bearing	15×32×8	1	
10	GB276,7000103	Deep racing ball bearing	17×35×8	2	
11	GB276;7000106	Deep racing ball bearing	30×55×9	2	
12	GB276;D7000110	Deep racing ball bearing	50×80×10	2	D
13	GB277,50202	Deep racing ball bearing with stop moving racing outside	15×35×11	1	
14	GB277;50204	Deep racing ball bearing with stop moving racing outside	20×47×14	3	
15	GB297;2007107E	Roller bearing	35×62×18	1	
16	GB301,8102	Thrust bearing	15×28×9	2	
17	GB301,8104	Thrust bearing	20×35×10	1	
18	GB301,8110	Thrust bearing	50×70×14	1	

4. Electrical system

4.1 Brief description

The machine with foreign advanced singlechip and superior quality electric element is controlled by electric system, the software system not only realize all kinds movement control ,but also has many protective function with catenation, the capability of this system is very good ,and the movement of this system is jarless and reliable.the move and stop of the main motor function are used by electric circuitry, and it improved the arrury of machine's drilling.

4.2 Explanation of the circuit

When using the machine,breaker QF1,QF2,QF3 which positioned electric box B1(drawing 4) must be closed,it can be opened when examined and repaired. The two breakers separately protect short circuit, over loading and short phase of spindle motor and pump motor .when close the chief switch QS1, the system is entering working state and the single lamp HL1 ligh up ,when break the chief electric source, the lamp crush out and working stopped.

4.3 Tapping operation:

Electric Element for the tapping control mainly contactors KM1 and KM2, selection switch SX1 and limit switches SQ2 and SQ3 for tapping depth control.put the selection switch SX1 into the "1"("0" is for hole drilling only),arrange the spindle revolution in clockwise direction (KM1 engaged), put the spindle manual opration lever in down position until touches work piece, tapping job noe is starting. When requied depth is reached , the limit switch SQ3 works, the spindle immediately runs in counter clockwise direction (KM2 engaged), the tap returns out of the work piece, when spindle returns to the up highest position ,the limit switch SQ2 works, spindle runs in clockwise direction, now one tapping job is finished. If tapping stop is required, push the button (SB4) on the lever end , the spindle motor will immediately run in count clockwise direction, that's all.

If the selection switch SX1 is in the "0"position, normal drilling work starts.

Attention: As the spindle motor works frequently during tapping,the motor will be hot quickly ,so the tapping job could not be down for a long time, eight times of tapping per minutes maximum is recommended as the motor needs cool when it is hot otherwise it will be burned.

4.4 Auto feed operation:

When auto feed , moving spindle down 5-6mm, press a push button at the end of either one of the three levers, now feed clutch is engaged and indicator HL2 on the panel is lighted auto feed job is started.

When required drilling depth is reached ,the limited switch will be pressed, then spindle returns automatically. Press the push button of the lever once angin, auto feed will be stopped and the spindle will return back to the original place.

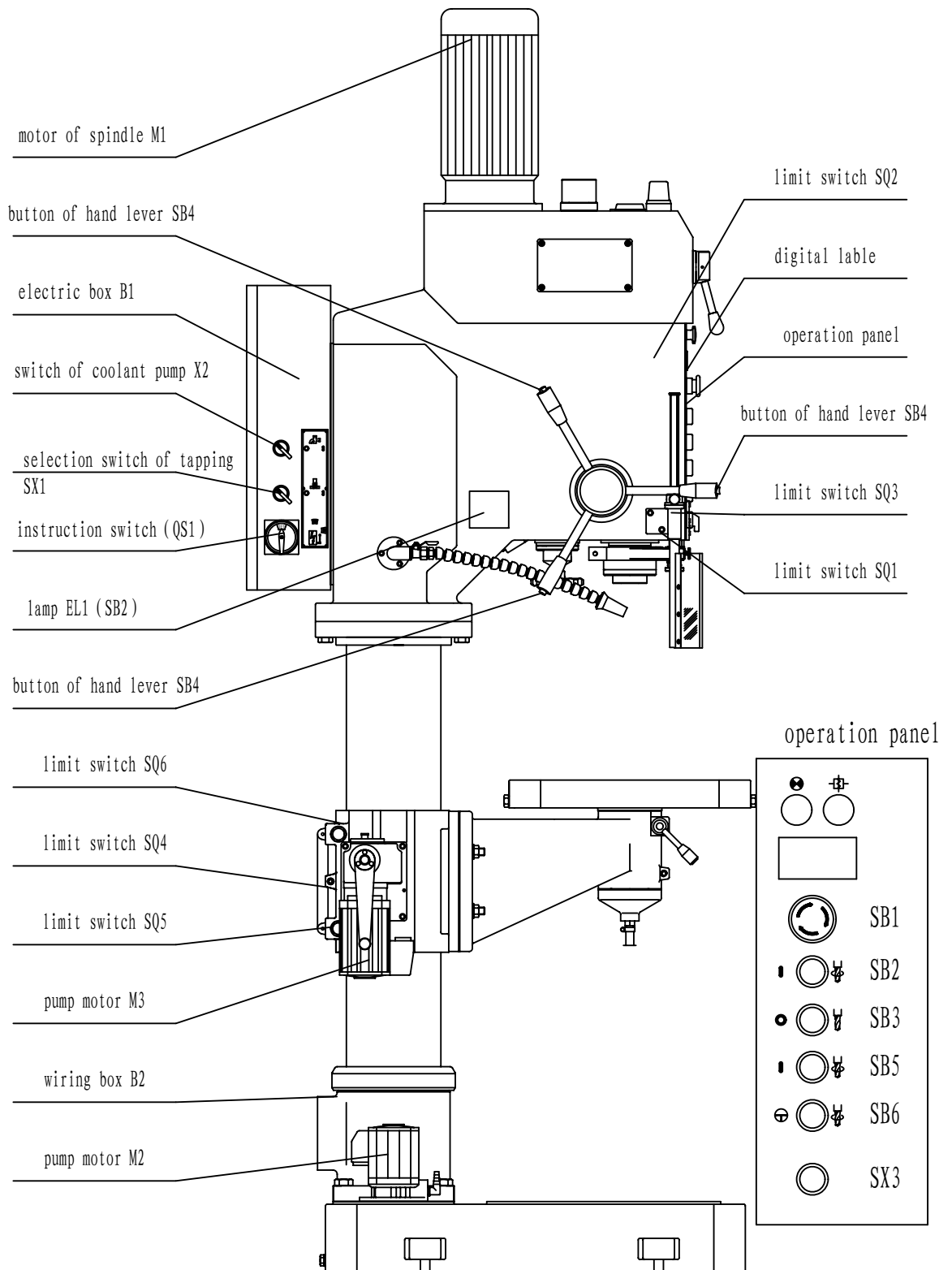

drawing (3) picture of electrical element of machine

4.5 Emergency stop operation:

If emergency stop is necessary during operation, press emergency push button SB1 that makes the loss of electric power of the contactor KM1,so the machine is completely stopped .After eliminating the breakdown ,release the lock of the push button then restart the machine.

4.6 Coolant pump

Revolving the switch of coolant pump right, then the coolant pump is moving and working with the spindle. When the spindle stopped, the coolant pump stopped too.

4.7 Lifting motor

The clamping handle 22 must be opened when the worktable lifting, turn the push button SX3 at required position.

4.8 Installation of the main motor:

Insert the key of the main motor into the solt position of the spline shaft then fixed by 4-M10 × 35 hex screw bolts. Connect three phases and one ground wires to the power supply as per the electrical Diagram(5) of the machine.(please note the direction of main revolving).

4.9 Sheet metal guard:

The sheet metal guard of this machine has a safety protection function, when it is opened The spindle can't working, until it is closed when the spindle is working now, it immediately stopped if The sheet metal guard is opened .

4.10 Maintenance of the electric equipment:

Turn off the electric power before maintenance of the electric equipment starts.The electric equipment must keep on clean condition. Therefore, regularly cleaning is necessary. However .liquid such as kerosene, gasoline and detergent etc.is not be allowed for the cleaning. Wave of power supply shall not be over $\pm 10\%$ required by the electric motor. Maintenance of electric equipment is absolutely important in order to keep machine works well.

total power supply	total switch	splind motor	pump motor	lifting motor	illumination	power supply control	lifting for table
--------------------	--------------	--------------	------------	---------------	--------------	----------------------	-------------------

3 φ AC400V 50HZ

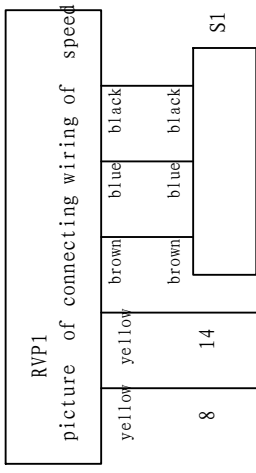
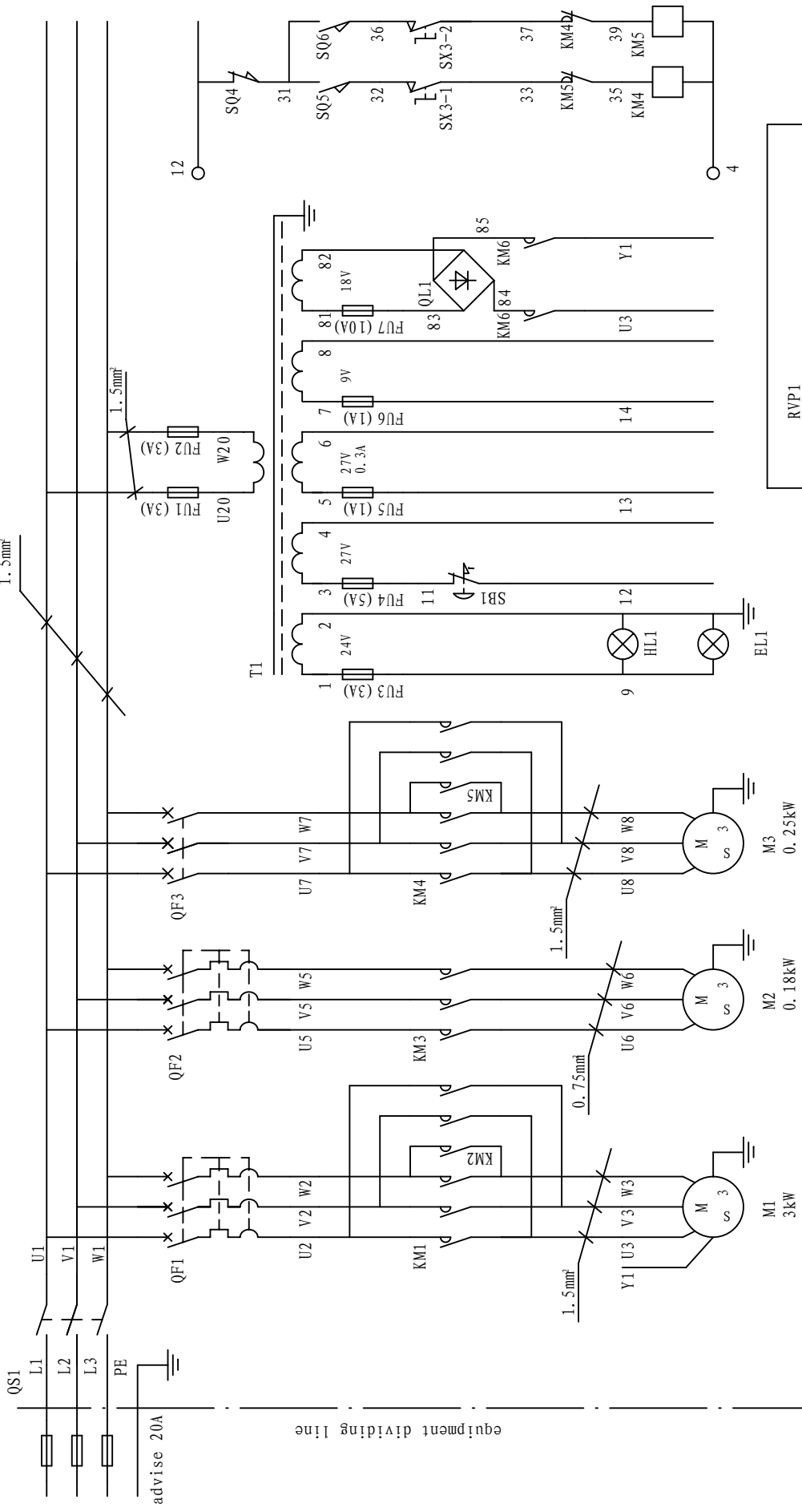

Attention: The diameter of the line without indicating is 0.75mm.

drawing (5-1) picture of electric element

P-14/13 Wiring Diagram

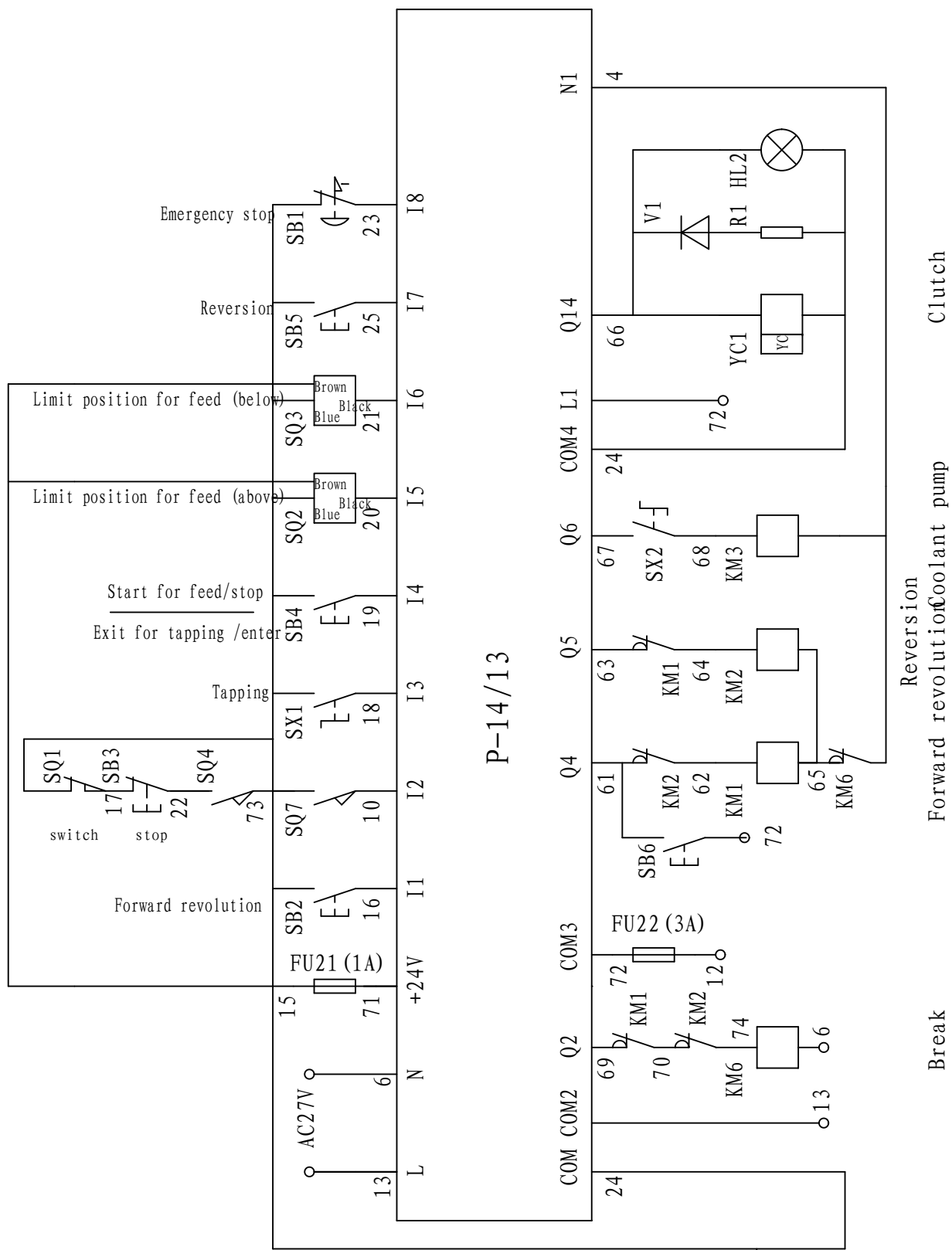

Attention: The diameter of the line without indicating is 0.75mm².

drawing (5-2) picture of electric element of machine

Model GHD-55PFAL	Operation Manual	Total	24
		page	14

Electric components list:

Table (3)

Code of elements	Name	Specification	Q'ty	Remark
QF1	Breaker	GV2-ME14C	1	
QF2	Breaker	JCM6-25-0.4/0.63A	1	
QF3	Breaker	DZ47-63 3P/3A	1	
QS1	Instruction switch	JCH13-20	1	
SX1,2	Selection switch	C2SS2-10B-10	2	
SB1	Emergency stop button	LA42J-02/R	1	
SB2,5	Push button	CP1-10G-10	2	
SB6	Push button	CP1-10B-10	1	
SB3	Push button	CP1-10R-01	1	
SB4	Push button	Homedade	1	
SX3	Selection push button	C3SS2-10B-20	1	
SQ1	Micro switch	LXP1-020-0A	1	
SQ5,SQ6	Micro switch	E62-10A	2	
SQ2,SQ3	Adjacent switch	TL-Q5MC1	2	
SQ4	Micro switch	XCKN2102P20C	1	
KM1-KM2	Contactor	LC1N1201B5N(AC24V)50Hz	2	
		LAEN02N	2	
KM3	Contactor	A2X12.2-30-11-24V	1	
KM4-KM6	Contactor	LC1N1201B5N(AC24V)50Hz	3	
HL1,HL2	Single lamp	AD17-16 AC24V	2	
EL1	Illuminating light	AC24V,25W	1	
T1	Transformer	JBK5-250TH, 400/24,27,27,9,18	1	
R1	Resistor	RT 2W62 Ω	1	
V1	Diode	IN5404	1	
U1	Control panel	WJ1-8/5F	1	
QL1	Bridge wiring	QL 10A 200V	1	
RVP1	Tachometer	RSD-22	1	
SQ7	Door switch	JWM6-11A	1	

5. Lubrication and coolant system:

Lubrication system:

Parts and bearings inside of the spindle box are all automatically lubricated. Oil level shall be a little bit higher than the centerline of the oil window when you fill lubrication oil. Too much oil filling will cause overflowing. Oil release plug and a filter device are in the same unit located at left side down of the spindle box. Please pay attention that when fastening your oil release plug, don't forget to put the oil absorption pipe inside of the filter, otherwise no filtered oil will be available. The filter needs to be washed once every two weeks.

For lubrication places and its requirements by manual. Please refer to the diagram 5.

Coolant system:

A special pump will supply coolant both for tool cutter and for work piece during machining. Coolant liquid is stored in a compartment located at the backside of the machine base. Flow rate of the coolant could be adjusted by a ball valve. Regularly washing for the coolant system is necessary and coolant water shall be exchanged as per actual condition.

6. Hoisting and installation:

Hoisting:

The machine is strongly fixed inside of the crate. When hoisting the machine, please pay close attention to the sign outside of the crate (where the wire cable shall be placed and where the gravity center is).

The crate must not be reversed or inclined and must not be strongly stroked when lift up the machine.

Considering small size of the bottom and higher size of the height of the machine package, therefore, moving the machine by roller is forbidden. Lifting by a crane or by forklift is recommended.

Please refer to the diagram 7 for the machine lifting. A soft pad between machine and wire cable is necessary in order to avoid paint damage of the machine. Lifting must be slow at beginning to see if the gravity center is correct.

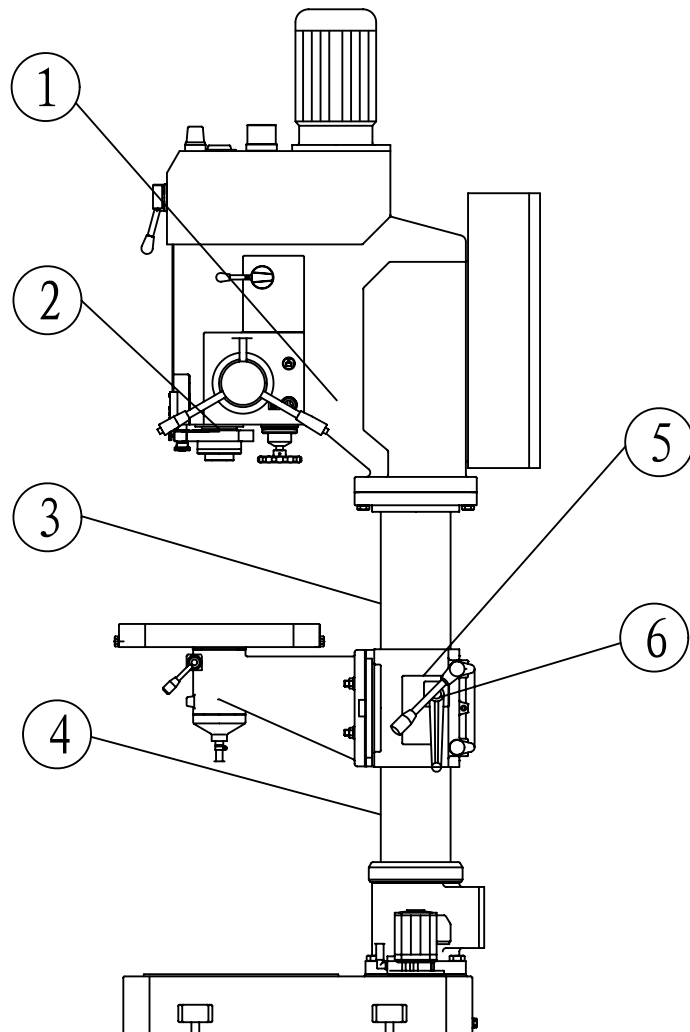

drawing 6 picture of lubrication

Chart of lubrication position

No.of lubrication position	lubrication position	lubrication period	Grease designation
1	Oil pool of spindlebox	Changing grease once every 6 month	No.40 lubricant
2	Surface of main spindle sleeve	Oiling once for each shift	
3	Surface of upright column	Oiling once for each shift	
4	Surface of upright column	Oiling once for each shift	
5	Carriage lifting device	Oiling once for each shift	
6	Worm bearing for carriage lifting	Oiling once for each shift	

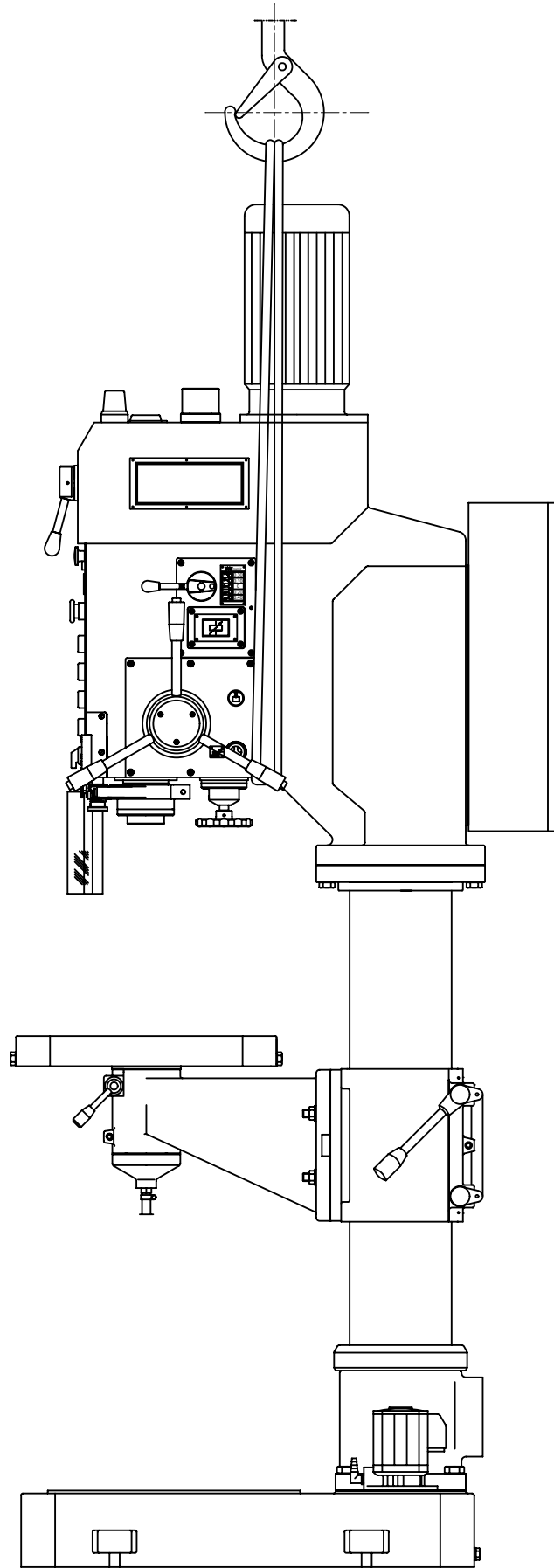

drawing 6. picture of hoisting

Installation:

Working area of the machine shall be the size when the worktable rounds its column in one cycle. Its diameter is about Ø2000mm. Further more, space for the work pieces, toolbox, and machine accessories as well as operating and maintenance space must be considered.

The machine should be placed on a solid ground. No foundation construction is required if ground of workshop is solid enough. However, we suggest that you'd better to make a foundation as per the attached drawing 8 and shall consider some space for foundation screw bolts use.

When the foundation is completely dry, the machine could be laid down on the adjustable pad. Concrete could be filled when screw bolts are placed. Fastening screw bolts after concrete is completely dry. Leveling the machine first, required tolerance should not be over 0.04/1000mm both in horizontal and cross plane. Checking all items of the accuracy as per the table sheet of the certificate. Accuracy value for each checked item must not be over the required value.

Preparation before machine running:

A strict checking, testing and try cutting of the machine have been made before machine delivery. No adjustment of the machine itself is necessary. Before machine running, clean all surfaces of the machine first by using cloth with kerosene or gasoline, checking all lubrication points then turn the main switch of the machine to the "on" position, running the machine with middle or slow speed and checking all revolution direction is correct, operating levers are in a correct position, checking machine noise and working temperature are all ok. The machine should be running for a certain period of time, then it could be used if no any un-normal condition happened.

7. Use and operation of the machine:

For the operating levers, handles, electric switches and buttons, please refer to the diagram 1 and diagram 4.

Mounting and dismounting of tool cutters:

The machine equipped with a tool dismounting device to be controlled by a nob (16). Push forward the nob (16) to the spindle box direction when tool mounting is required. As for dismounting tool cutters, pull out the nob (16), hold the tool cutter by left hand, meanwhile, turn the feed lever (4) by right hand, then the spindle quill goes up rapidly, the tool cutter will fall down until tool taper shank strokes the shaft of spindle.

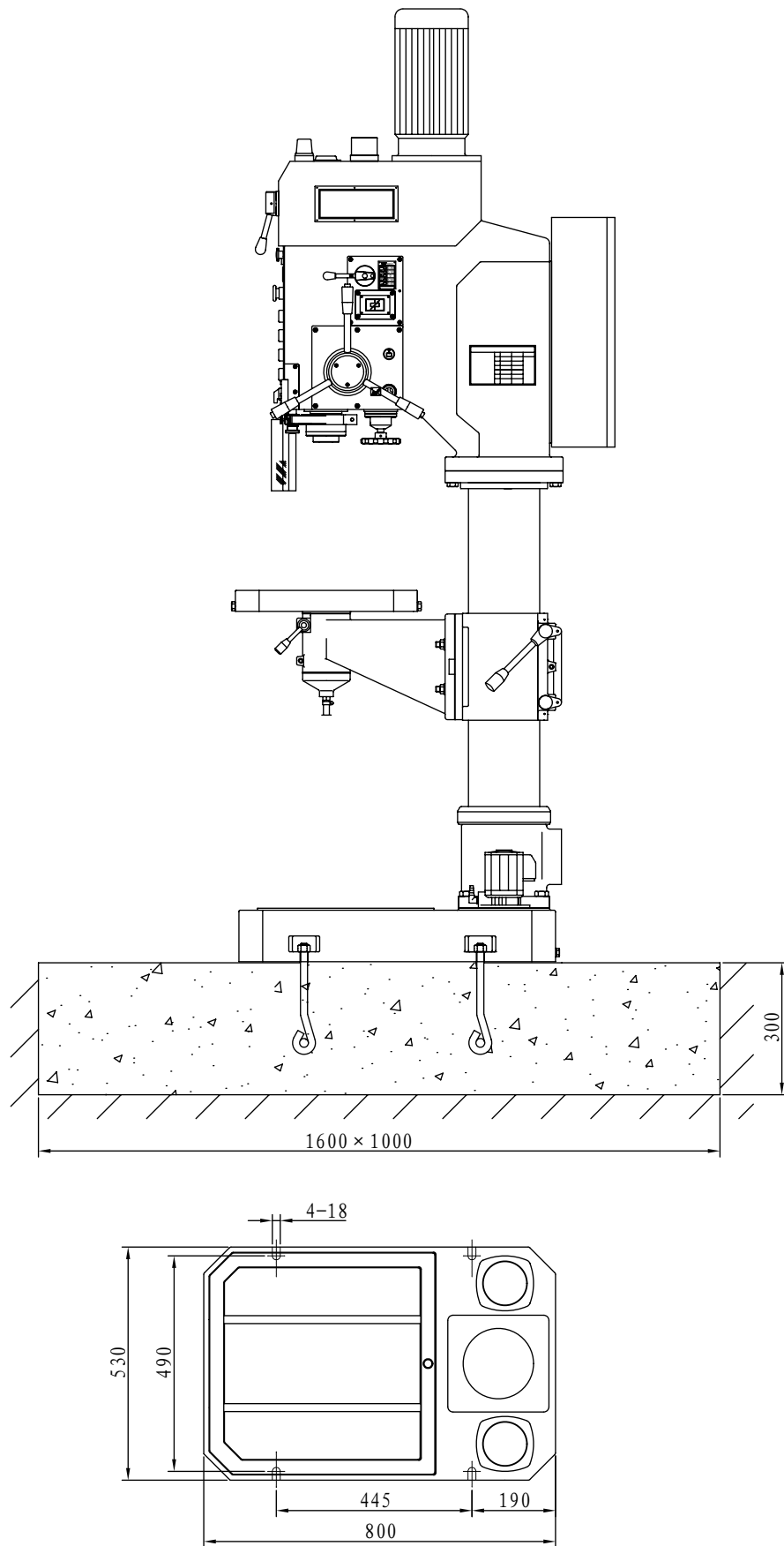

drawing 8 picture of installation of machine

In case too tight mesh between tool shank and spindle taper and the tool cutter could not fall down after several strokes, then you have to use the normal way by using a taper wedge to dismounting the tool cutter.

If milling cutter is used, be sure to take away the screw on the tool holder screwed on the end of the spindle, the milling cutter then could be easily dismounted.

Warning: The nob (16) must not be pulled out while tool mounting or machine Running, otherwise, the spindle will goes up quickly which results tool cutter falls down. It is really dangerous.

7.3 Changes for the spindle speed and feed rate:

Spindle speed change could be made by moving the two levers (14) and (15) located in the front of the spindle box. Relations between spindle speed revolution and levers position is indicated at the speed change label. Meanwhile, the digital meter indicates the actual spindle revolution.

As mounting or dismounting tool cutter or adjustment of work piece needs spindle rotation by manual, therefore, the lever in the right side position shall be in the “idle” position, so spindle rotation could be easily obtained.

Changes of the feed rate could be realized by using the lever (5) in the upper right side position of the spindle box. As micro manual feed needs disengagement of the auto feed, therefore, the lever shall also be in the “idle” position.

7.4 Selection and operation of the spindle feed:

There are three types of spindle feed selections for your choice as per the requirement of your machining:

Manual feed: Simply moving the feed lever(4)at the right side of the spindle box, the spindle will move down if turned the lever in counter clockwise and the spindle will move up if turned the lever in clockwise.

Auto feed: There are three levers(4),at the end of each lever equipped with a push button.Push one of any three buttons(SB4), auto feed could be realized as per your required pre-set feed rate. Push one of any three buttons(SB4) once again, the auto feed will be stopped immediately.

Manual micro feed: Spindle micro feed needs two steps. First, put the feed rate lever(5)in the “idle” position. Secondly, push button (SB4), then push up the micro feed hand wheel(3) and make sure that the clutch is engaged, now the micro feed hand wheel could be turned and micro feed of the spindle works.

7.5 Cutting depth control:

For the batch production, you need control cutting depth. A scale in front of spindle box could meet your requirements. Loosening knurled screw (20) by turning nob (2), moving the scale to the required depth, then fastening the knurled screw(20). Now the machining depth could be controlled.

7.6 Application of the digital scale:

A small round battery is fixed on the right side position of the spindle box for digital readout. With this scale, moving distance of the spindle could be easily readout. Except the battery switch, a “reset” push button and an “English or Metric” converter push button are available. Cutting depth could be readout at any time and cutting depth could also be set in advance. This function will be helpful for small batch or single work piece machining.

7.7 Tapping:

Put the “Selection Switch”(18) on the tapping position first, turn the feed lever(4) and let the tap approaches the work piece, a proper manpower force (based on the size of screw) shall be exerted in order to let the tap comes into the hole. The spindle will be rotated in reverse when the screw depth is reached, and the tap comes out.

Suppose, tapping job needs stop, push button (SB4) of the hand lever(4) then spindle will have reverse revolution. and tap returns back.

7.8 Milling

Choosing milling cutters and accessories as per the machining requirements and shape of the work piece. Milling cutters could be fixed on the spindle via tool holder or drill check. Put accessories on the worktable and fasten it, turn the worktable and let its pin in the bottom approaches right side position of round column and let lock block clamps the pin and fastens it by screw, be sure to clamp it in force by clamping levers(6) and (22) .

For the milling operation, manual feed or auto feed using lever(4) is not permitted. The best way is to use micro feed hand wheel(3). Lock spindle by turning a clamping rod(6) if required cutting depth is reached. Now milling operation could be started.

Warning: The clamping rod (6) is to be used only for clamping the spindle while Milling. Therefore, for the job of drilling or tapping, the clamping rod shall be released. Otherwise, the spindle quill could not be moved and quill surface will be destroyed.

7.9 Adjustment of worktable position:

Symbols multi-use and convenience of the machine also reflects multi function of its worktable. Except its normal manual and auto up and down function, it can also be turned around the table itself, around the column and tilt in $\pm 45^\circ$ in horizontal position.

Operation method for the table tilting

Using a special tool to take out the taper pin and loosening four screw nuts on the bracket and manually turn the worktable to the required position then fastening the four screw nuts, now the work piece can be machined as per your tilting angle.

When the job is finished, keep the worktable in the original position by using the same way mentioned on the above. Be sure do not forget to push the pin in its position.

8. Machine adjustment:

8.1 Spindle balance force adjustment:

Balance of spindle is realized through a springiness from a coil spring device located at the left side of the spindle box. Balance force shall be adjusted to the point that the spindle together with its tool shall not go down itself when spindle stops. (go up a little bit shall be much better).

Over springiness or less needs adjustment. Simply loosening the screw on the cover of spring box, turn the spring box cover, the spring could be either fastening or loosening. Fastening screw on the cover if the balance force is ok

8.2 Adjustment for the feed safety clutch:

Feed safety clutch is mounted on upper side of the worm shaft. If too much feed resisting force is occurred, the feed safety clutch will be automatically slipped (sound "Ka" will be heard) in order to protect machine driving system not to be damaged. Clutch appearance could be seen when opening the cover below the feed change label.

Using a tool to turn a slotted nut in clockwise, this will increase the feed resisting force, meanwhile, the counter clockwise will reduce the feed resisting force. The max. feed resisting force of this machine is 10000N, Over feed resisting force will cause un-safety, be sure to lock it by screw bolt or nut after adjustment.

9 Machine use and maintenance:

- 9.1 Before running the machine, carefully read the Operation Manual first, fully understand the structure of the machine and its performance and needs to familiar with locations for all levers and buttons.
- 9.2 Lubrication of the machine is very important. Daily lubrication work as per the requirements of the operation manual is necessary. Filter should be cleaned once every two weeks otherwise pump, transmission parts and bearings will be damaged.
- 9.3 Max. spindle torque of this machine is 160Nm. Max. feed resisting force in the driving system is 10000N. Over permitted cutting feed range is not allowed. High spindle speed with big cutting feed is not good to the machine.
- 9.4 As standard drill with 118 degree angle features big cutting force but quick wear-out, so diameter and roughness of holes is not so ideal after drilling, therefore, regrinding its edges particularly for the big diameter drills is necessary. It is better to use two different angles for the machining of cast iron material (Second angle could be 70°).
- 9.5 Spot facer with three edges is proffered for the spot facing machining, using a normal drill for spot facing job will cause vibration. However, it will have a better result for the spot facing machining if reducing the rear angle of the normal drill with two different angles and going down the cutting speed and feed rate.
- 9.6 Temperature of motor will be increased so quickly when tapping due to frequently Motor direction be changed. Therefore, rapid and continuous tapping shall be avoided. Max. eight times per minutes of tapping is recommended. The machine shall be stopped for cooling if the motor is too hot.
- 9.7 A proper cutting force is required when milling. As this is not a milling machine although it has a milling function. Too big milling force will cause worktable moving round the column, therefore, clamping the worktable strongly is required when milling and a reasonable cutting feed rate for milling job is necessary.
- 9.8 Please turn off the coolant valve when mounting and dismounting tools, clamping or adjusting work piece or measuring work piece, as coolant is not necessary during this period. Stop coolant pump if these job takes more than ten minutes.
- 9.9 As gears are to be used for spindle and feed system, so it is not allowed to change spindle speed or change cutting feed rate when machine running, otherwise it will damage gears, shafts or relevant parts.

Operation Manual	Total	24
	page	24

9.10 Do not extend spindle quill too much, instead, a proper working table height is suggested .Clean the spindle taper hole and tool taper shank first before tool mounting. Unqualified or rusted or damaged taper shank is forbidden to use.

9.11 Dry agent inside of the electric box and regularly removing dustiness are necessary. It is forbidden to us gasoline or kerosene or diesel oil to clean electric components. We suggest to use those no erosion and not be easily burned liquid such as carbon tetrachloride etc.

11. Machine accessories:

No.	Description	Specification/standard	Q'ty	Remark
1	Drill check with spanner	1-13/G86087	1	
2	Adapter for drill check		1	
3	Adaptor	4-3/JB3477	1	
4	Adaptor	4-2/JB3477	1	
5	Adaptor	3-1/JB3477	1	
6	Taper wedge for flat shape quill	Wedge 1/JB3482	1	
7	Taper wedge for flat shape quill	Wedge 3/JB3482	1	
8	Wrench	21×24/GB4388	1	
9	Battery	SR44	1	
10	Fuse	φ 5×25 3A/1A/10A	2 for each	
11	Fuse	φ 5×25 5A	2	
12	Cross work table	640×205	1	Special attachment
13	Cross work table	555×195	1	Special attachment
14	End cutter	φ 80×27/GB5342	1	Special attachment
15	Milling shank		1	Special attachment
16	adaptor for spring collet		1	Special attachment
17	Nut for T-slot	M12	4	Special attachment
18	Inner hexagon bolt	M12×40	4	Special attachment
19	Spring collet	6,8,10,12,15,16	1	Special attachment

Vertical Drilling Machine

Model: GHD-55PFAL

Certificate of Inspection

Max. Drilling Diameter: 50mm

Series Number:

We certified that the machine has been inspected and all items of the machine are in conformity With Q/320684FNC01-2016 standard. Delivery is permitted.

Director of the company:

Date:

Director of quality inspection department:

Date:

Precision Inspection Record

Geometrical Precision Test:

No.	Item	Brief Drawing	Precision	
			Allowance (mm)	Actual Test
G1	Parallelism of the base surface		0.06 at any tested Length of 300 (flat or concave)	
G2	Parallelism of the work table surface		0.04 at any tested Length of 300 (flat or concave)	
G3	surface runout of worktable		D=300 0.04	

Precision Inspection Record

Geometrical Precision Test:

No.	Item	Brief Drawing	Precision	
			Allowance (mm)	Actual Test
G4	Spindle bore axis runout a) Close to spindle surface b) at a distance of L to spindle surface		L=200 a) 0.02 b) 0.035	
G5	Perpendicularity of the spindle axis to work table surface		a) 0.1/300* (a ≤ 90°) b) 0.06/300*	
G6	Perpendicularity of the spindle axis to Base plate table surface		a) 0.10/300* (a ≤ 90°) b) 0.10/300*	

Distance between two contacts of indicator probe

Precision Inspection Record

Geometrical Precision Test:

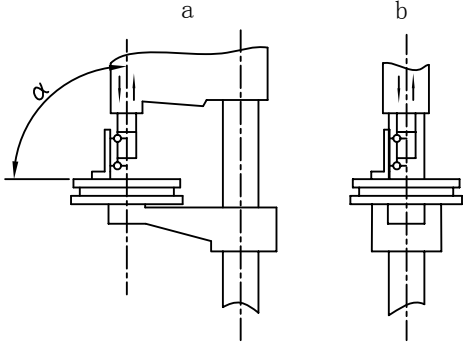
No.	Item	Brief Drawing	Precision	
			Allowance (mm)	Actual Test
G7	Perpendicularity of the vertical movement of spindle sleeve to work table surface		a.0.1/300 (a≤90°) b.0.1/300	

Work Accuracy:

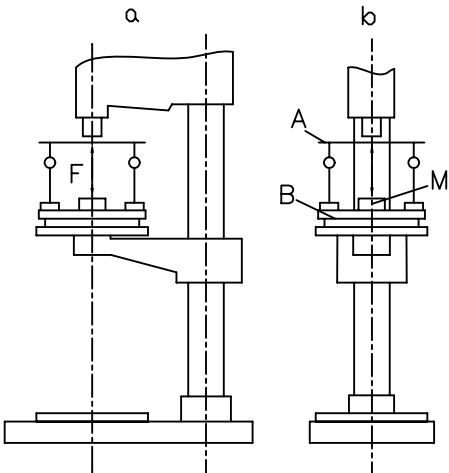
P1	The change of Perpendicularity of spindle axis to work table surface under the axial force.		F=10000N 2/1000	
----	---	--	--------------------	--

--	--	--	--	--

Vertical Drilling Machine

Model: GHD-55PFAL

Packing list

Max. Drilling Diameter: 50mm

Series Number:

Packing list	Total	1
	page	1

Case No.: 1/1

Packing Dimension (L ×W × H): 1150×680 ×2250 CM

Gross weight:645kg

Net weight: 615kg

No.	Name	Specification and marks	Q'ty	Remark
1	Machine		1 piece	
2	Drill check with lever	1-13: GB6087	1 piece	
3	Drill check adaptor	MT4-B16	1 piece	
4	Tool shank adaptor	4-3: JB3477	1 piece	
		4-2: JB3477	1 piece	
		3-1: JB3477	1 piece	
5	Taper wedge for shank	Wedge 1: JB3482	1 piece	
		Wedge 3: JB3482	1 piece	
6	Wrench	21×24/GB4388	1	
7	Battery	Cr2032-32	1	
8	Fuse	φ 5×25 3A/1A/5A/10A	2 for each	
9	Cross work table	640×205	1	Special attachment
10	Cross work table	555×195	1	Special attachment
11	End cutter	φ 80×27/GB5342	1	Special attachment
12	Milling shank		1	Special attachment
13	adaptor for spring collet		1	Special attachment
14	Nut for T-slot	M12	4	Special attachment
15	Inner hexagon bolt	M12×40	4	Special attachment
16	Spring collet	6,8,10,12,15,16	1	Special attachment
17	Operation manual		1 piece	
	Quality certificate		1 piece	
	Packing list		1 piece	

Inspector of the packing:

Date:

Vertical Drilling Machine

Model: GHD-55PFAL

Ancillary page of Operation Manual

Max. Drilling Diameter: 50mm

Series Number:

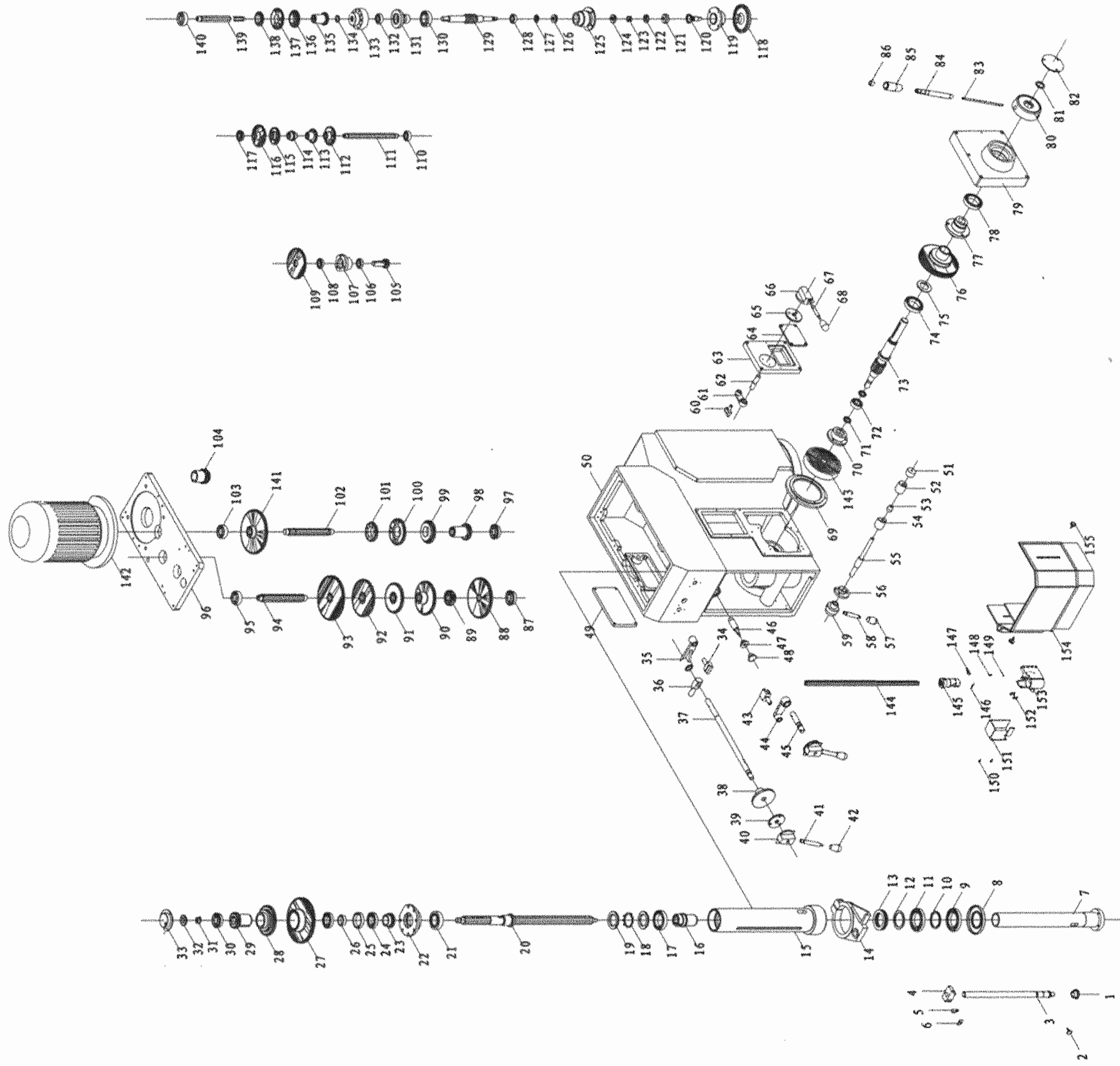

drawing (1) Picture of dimension of spindle box parts structure

Spindle box assembly

Index No.	Part No.	Description	Size	Qty.
1	GHD55PFAL-1001	Knurled knob		1
2	GHD55PFAL-1002	Knurled screw bolt		1
3	GHD55PFAL-1003	Scaled screw		1
4	GHD55PFAL-1004	Scaled nut		1
5	GHD55PFAL-1005	Support for the vernier		1
6	GHD55PFAL-1006	Scaled indicator sheet		1
7	GHD55PFAL-1007	Main spindle		1
8	GHD55PFAL-1008	Bearing cover		1
9	GHD55PFAL-1009	Bearing	D7000110	1
10	GHD55PFAL-1010	Washer		1
11	GHD55PFAL-1009	Bearing	D7000110	1
12	GHD55PFAL-1012	Washer		1
13	GHD55PFAL-1013	Bearing		1
14	GHD55PFAL-1014	Scale clamper		1
15	GHD55PFAL-1015	Spindle quill		1
16	GHD55PFAL-1016	Spline quill		1
17	GHD55PFAL-1017	Bearing	D7000909	1
18	GHD55PFAL-1018	Washer		1
19	GHD55PFAL-1019	Round nut		2
20	GHD55PFAL-1020	Transmission shaft		1
21	GHD55PFAL-1021	Bearing	2007107E	1
22	GHD55PFAL-1022	Bearing cover		1
23	GHD55PFAL-1023	Feed gear		1
24	GHD55PFAL-1024	Bearing	7000106	2
25	GHD55PFAL-1025	Bushing		1
26	GHD55PFAL-1026	Bearing		1
27	GHD55PFAL-1027	Gear		1
28	GHD55PFAL-1028	Gear		1
29	GHD55PFAL-1029	Gear		1
30	GHD55PFAL-1030	Bearing	50204	1
31	GHD55PFAL-1031	Washer	18	1
32	GHD55PFAL-1032	Round nut		1
33	GHD55PFAL-1033	Cover		1
34	GHD55PFAL-1034	Lever block		1
35	GHD55PFAL-1035	Fork lever		1
36	GHD55PFAL-1036	Support for block		1
37	GHD55PFAL-1037	Lever shaft		1
38	GHD55PFAL-1038	Positioning twist		1
39	GHD55PFAL-1039	Washer		2
40	GHD55PFAL-1040	Handle seat		2
41	GHD55PFAL-1041	Handle		2
42	GHD55PFAL-1042	Oval knob		2
43	GHD55PFAL-1043	Lever block		1
44	GHD55PFAL-1044	Fork lever		1
45	GHD55PFAL-1045	Lever shaft		1
46	GHD55PFAL-1046	Positioning shaft		1
47	GHD55PFAL-1047	Bushing		1
48	GHD55PFAL-1048	Knurled handle	BM8x32	1
49	GHD55PFAL-1049	Cover		1
50	GHD55PFAL-1050	Spindle box		1
51	GHD55PFAL-1051	Stop ring		1

Index No.	Part No.	Description	Size	Qty.
52	GHD55PFAL-1052	Lock sleeve(II)		1
53	GHD55PFAL-1053	Sleeve		1
54	GHD55PFAL-1054	Lock sleeve(I)		1
55	GHD55PFAL-1055	Locked screw		1
56	GHD55PFAL-1056	Eccentric cover		1
57	GHD55PFAL-1057	Oval knob		1
58	GHD55PFAL-1058	Handle		1
59	GHD55PFAL-1059	Handle seat		1
60	GHD55PFAL-1060	Lever block		1
61	GHD55PFAL-1061	Fork lever		1
62	GHD55PFAL-1062	Small shaft		1
63	GHD55PFAL-1063	Side cover		1
64	GHD55PFAL-1064	Cover		1
65	GHD55PFAL-1065	Positioning board		1
66	GHD55PFAL-1066	Handle seat		1
67	GHD55PFAL-1067	Handle lever		1
68	GHD55PFAL-1068	Oval knob		1
69	GHD55PFAL-1069	Cover		1
70	GHD55PFAL-1070	Bearing cover		1
71	GHD55PFAL-1071	Washer		2
72	GHD55PFAL-1072	Bearing	104	1
73	GHD55PFAL-1073	Horizontal spindle		1
74	GHD55PFAL-1074	Bearing	1000909	1
75	GHD55PFAL-1075	Washer		1
76	GHD55PFAL-1076	Worm wheel		1
77	GHD55PFAL-1077	Sleeve		1
78	GHD55PFAL-1074	Bearing	1000909	1
79	GHD55PFAL-1079	Side cover for feed		1
80	GHD55PFAL-1080	Handle seat		1
81	GHD55PFAL-1081	Washer for adjusting		1
82	GHD55PFAL-1082	Pressing cover		1
83	GHD55PFAL-1083	Lever		3
84	GHD55PFAL-1084	Handle lever		3
85	GHD55PFAL-1085	Nip		3
86	GHD55PFAL-1086	Core lever		3
87	GHD55PFAL-1030	Bearing	50204	1
88	GHD55PFAL-1088	Gear		1
89	GHD55PFAL-1089	Gear		1
90	GHD55PFAL-1090	Gear		1
91	GHD55PFAL-1091	Gear		1
92	GHD55PFAL-1092	Gear		1
93	GHD55PFAL-1093	Gear		1
94	GHD55PFAL-1094	Spline (II)		1
95	GHD55PFAL-1095	Bearing	204	1
96	GHD55PFAL-1096	Spindle box cover		1
97	GHD55PFAL-1030	Bearing	50204	1
98	GHD55PFAL-1098	Gear		1
99	GHD55PFAL-1099	Gear		1
100	GHD55PFAL-1100	Gear		1
101	GHD55PFAL-1101	Gear		1
102	GHD55PFAL-1102	Spline shaft (I)		1
103	GHD55PFAL-1095	Bearing	204	1
104	GHD55PFAL-1104	Electric gear		1

Index No.	Part No.	Description	Size	Qty.
105	GHD55PFAL-1105	Feed gear		1
106	GHD55PFAL-1106	Bearing		1
107	GHD55PFAL-1107	Bearing seat		1
108	GHD55PFAL-1108	Bearing		1
109	GHD55PFAL-1109	Feed gear		1
110	GHD55PFAL-1110	Bearing	202	1
111	GHD55PFAL-1111	Spline shaft (III)		1
112	GHD55PFAL-1112	Feed gear		1
113	GHD55PFAL-1113	Feed gear		1
114	GHD55PFAL-1114	Feed gear		1
115	GHD55PFAL-1115	Feed gear		1
116	GHD55PFAL-1116	Feed gear		1
117	GHD55PFAL-1117	Bearing		1
118	GHD55PFAL-1118	Waved hand wheel		1
119	GHD55PFAL-1119	Worm cover		1
120	GHD55PFAL-1120	Inching shaft		1
121	GHD55PFAL-1121	Inching clutch		1
122	GHD55PFAL-1122	Round nut	M14x1.5	1
123	GHD55PFAL-1123	Washer	14	1
124	GHD55PFAL-1124	Bearing	8102	1
125	GHD55PFAL-1125	Bearing seat		1
126	GHD55PFAL-1124	Bearing	8102	1
127	GHD55PFAL-1127	Washer		1
128	GHD55PFAL-1128	Bearing	102	1
129	GHD55PFAL-1129	Worm shaft		1
130	GHD55PFAL-1130	Bearing	106	1
131	GHD55PFAL-1131	Clutch seat (below)		1
132	GHD55PFAL-1132	Bearing	202	1
133	GHD55PFAL-1133	Overload protection sleeve		1
134	GHD55PFAL-1134	Washer for adjusting		1
135	GHD55PFAL-1135	Feed gear		1
136	GHD55PFAL-1136	Feed gear		1
137	GHD55PFAL-1137	Feed gear		1
138	GHD55PFAL-1138	Feed gear		1
139	GHD55PFAL-1139	Spline shaft (IV)		1
140	GHD55PFAL-1140	Ball bearing	303	1
141	GHD55PFAL-1141	Gear		1
142	GHD55PFAL-1142	Electric Motor		1
143	GHD55PFAL-1143	Flat Spring		1
144	GHD55PFAL-1144	Support Rod		1
145	GHD55PFAL-1145	Turn the sleeve		1
146	GHD55PFAL-1146	Cylinder pin	4x25	1
147	GHD55PFAL-1147	Leverage		1
148	GHD55PFAL-1148	Small ejector pin		1
149	GHD55PFAL-1149	Steel Ball		1
150	GHD55PFAL-1150	Screws	M4x30	2
151	GHD55PFAL-1151	Sheet metal cover		1
152	GHD55PFAL-1152	Screws	M4x8	4
153	GHD55PFAL-1153	Stent		1
154	GHD55PFAL-1154	Shields		1
155	GHD55PFAL-1155	Set screws		1

Drawing (2) Picture of dimensions sketch of column and bracket parts structure

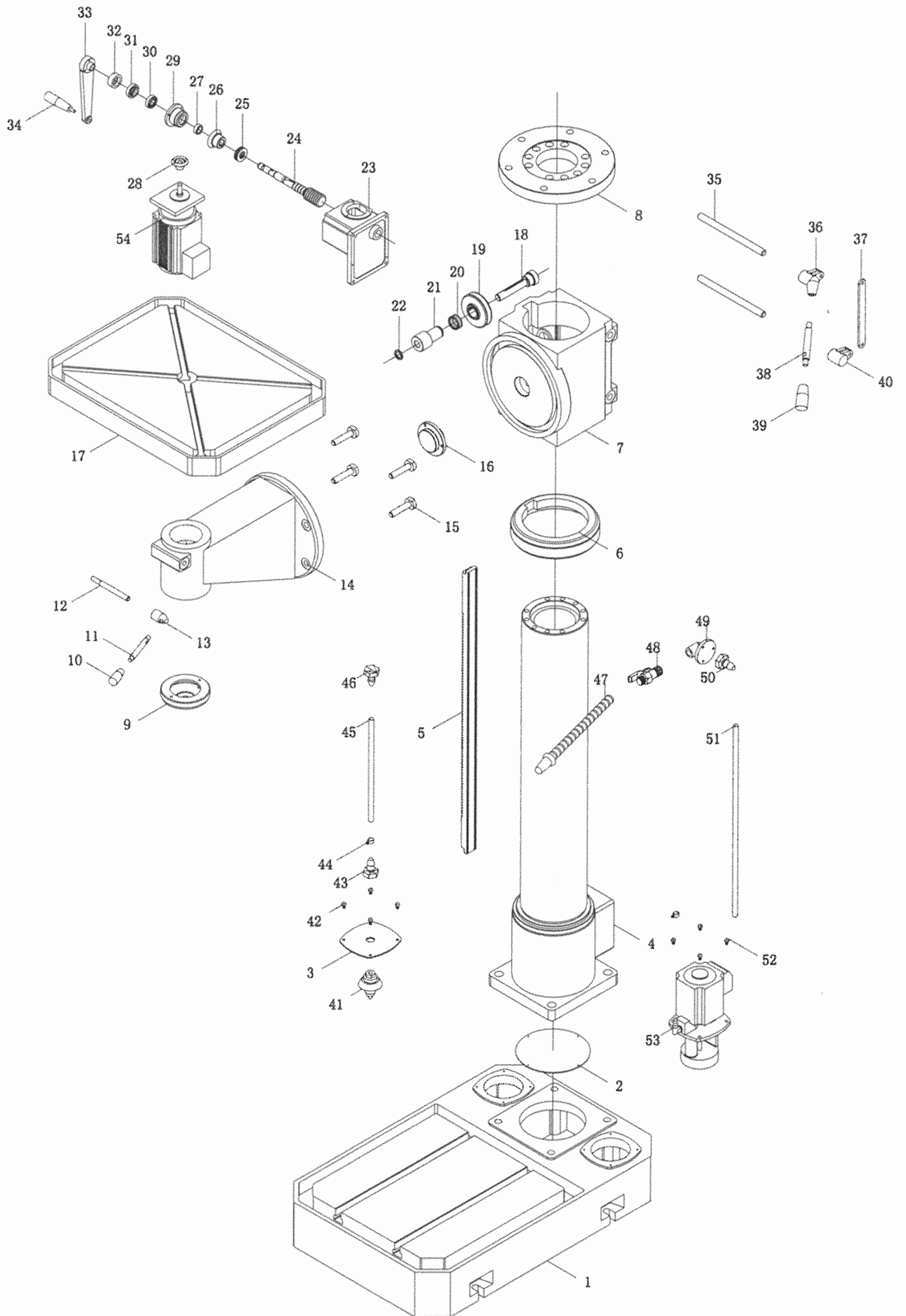

Column and its bracket assembly

Index No.	Part No.	Description	Size	Qty.
1	GHD55PFAL-2001	Base		1
2	GHD55PFAL-2002	Cover		1
3	GHD55PFAL-2003	Cover broad		1
4	GHD55PFAL-2004	Column		1
5	GHD55PFAL-2005	Rack		1
6	GHD55PFAL-2006	Stop ring		1
7	GHD55PFAL-2007	Up and down device of bracket		1
8	GHD55PFAL-2008	Up connection seat		1
9	GHD55PFAL-2009	Crust		1
10	GHD55PFAL-2010	Long lever quill	M10×50	1
11	GHD55PFAL-2011	Hand lever	M10×80	1
12	GHD55PFAL-2012	Double end bolt		1
13	GHD55PFAL-2013	Hand lever seat	M12×30	1
14	GHD55PFAL-2014	Bracket seat		1
15	GHD55PFAL-2015	T type screw bolt		1
16	GHD55PFAL-2016	Positioning shaft		1
17	GHD55PFAL-2017	Worktable		1
18	GHD55PFAL-2018	Small shaft		1
19	GHD55PFAL-2019	Worm shaft		1
20	GHD55PFAL-2020	Sleeve		1
21	GHD55PFAL-2021	Gear		1
22	GHD55PFAL-2022	Washer		1
23	GHD55PFAL-2023	Side cover for lifting		1
24	GHD55PFAL-2024	Warm shaft for lifting		1
25	GHD55PFAL-2025	Ball bearing	8104	1
26	GHD55PFAL-2026	Taper gear		1
27	GHD55PFAL-2027	Washer for adjusting		1
28	GHD55PFAL-2028	Taper gear		1
29	GHD55PFAL-2029	Bearing seat		1
30	GHD55PFAL-2030	Ball bearing of depth chimb	7000102	1
31	GHD55PFAL-2031	Connecting end		1
32	GHD55PFAL-2032	Connecting end		1
33	GHD55PFAL-2033	Lever for lifting		1
34	GHD55PFAL-2034	Lever for turning	M10×80	1
35	GHD55PFAL-2035	Double end bolt		2
36	GHD55PFAL-2036	Main nut for clamping board		1
37	GHD55PFAL-2037	Connecting board for bracket		1
38	GHD55PFAL-2038	Hand lever	M10×100	1
39	GHD55PFAL-2039	Long hand quill	M12×60	1
40	GHD55PFAL-2040	Nut for clamping board		1
41	GHD55PFAL-2041	Water filters		1
42	GHD55PFAL-2042	Slotted cylindrical head screws		4
43	GHD55PFAL-2043	Rubber hose straight fitting		1
44	GHD55PFAL-2044	Throat band		3
45	GHD55PFAL-2045	Fiber reinforced nylon		1
46	GHD55PFAL-2046	Rubber hose straight fitting		1
47	GHD55PFAL-2047	Plastic cooling pipe		1
48	GHD55PFAL-2048	Copper Ball valve		1
49	GHD55PFAL-2049	Right angle joint		1

Index No.	Part No.	Description	Size	Qty.
50	GHD55PFAL-2050	Rubber hose straight fitting		1
51	GHD55PFAL-2051	Fiber reinforced nylon		1
52	GHD55PFAL-2052	Slotted cylindrical head screws		4
53	GHD-25-2-06	Cooling pump		1
54	GHD55PFAL-2054	Lift Motor		1

GB - ENGLISH

Environmental protection

Protect the environment.

Your appliance contains valuable materials which can be recovered or recycled. Please leave it at a specialized institution.



This symbol indicates separate collection for electrical and electronic equipment required under the WEEE Directive (Directive 2012/19/EC) and is effective only within the European Union.

DE - DEUTSCH

Umweltschutz

Schützen Sie die Umwelt!

Ihr Gerät enthält mehrere unterschiedliche, wiederverwertbare Werkstoffe.
Bitte entsorgen Sie es nur an einer spezialisierten Entsorgungsstelle.



Dieses Symbol verweist auf die getrennte Sammlung von Elektro- und Elektronikgeräten, gemäß Forderung der WEEE-Richtlinie (2012/19/EU). Diese Richtlinie ist nur innerhalb der Europäischen Union wirksam.

FR - FRANCE

Protection de l'environnement

Protégez l'environnement !

Votre appareil comprend plusieurs matières premières différentes et recyclables. Pour éliminer l'appareil usagé, veuillez l'apporter dans un centre spécialisé de recyclage des appareils électriques.



Ce symbole indique une collecte séparée des équipements électriques et électroniques conformément à la directive DEEE (2012/19/UE). Cette directive n'est efficace que dans l'Union européenne.



Warranty / Garantie

JPW Tool Group Hong Kong Limited guarantees that the supplied product(s) is/are free from material defects and manufacturing faults.

This warranty does not cover any defects which are caused, either directly or indirectly, by incorrect use, carelessness, damage due to accidents, repairs or inadequate maintenance or cleaning as well as normal wear and tear.

Further details on warranty (e.g. warranty period) can be found in the General Terms and Conditions (GTC) that are an integral part of the contract.

These GTC may be viewed on the website of your dealer or sent to you upon request.

JPW Tool Group Hong Kong Limited reserves the right to make changes to the product and accessories at any time.

JPW Tool Group Hong Kong Limited garantiert, dass das/die von ihr gelieferte/n Produkt/e frei von Material- und Herstellungsfehlern ist.

Diese Garantie deckt keinerlei Mängel, Schäden und Fehler ab, die - direkt oder indirekt - durch falsche oder nicht sachgemäße Verwendung, Fahrlässigkeit, Unfallschäden, Reparaturen oder unzureichende Wartungs- oder Reinigungsarbeiten sowie durch natürliche Abnutzung durch den Gebrauch verursacht werden.

Weitere Einzelheiten zur Garantie können den allgemeinen Geschäftsbedingungen (AGB) entnommen werden.

Diese können Ihnen auf Wunsch per Post oder Mail zugesendet werden.

JPW Tool Group Hong Kong Limited behält sich das Recht vor, jederzeit Änderungen am Produkt und am Zubehör vorzunehmen.

JPW Tool Group Hong Kong Limited garantit que le/les produit(s)fourni(s) est/sont exempt(s) de défauts matériels et de défauts de fabrication.

Cette garantie ne couvre pas les défauts, dommages et défaillances causés, directement ou indirectement, par l'utilisation incorrecte ou inadéquate, la négligence, les dommages accidentels, la réparation, la maintenance ou le nettoyage incorrects et l'usure normale.

Vous pouvez trouver de plus amples détails sur la garantie dans les conditions générales (CG).

Les CG peuvent être envoyées sur demande par poste ou par e-mail .

JPW Tool Group Hong Kong Limited se réserve le droit d'effectuer des changements sur le produit et les accessoires à tout moment.



JPW Tool Group Hong Kong Limited

98 Granville Road, Tsimshatsui East, Kowloon, Hong Kong, PRC

www.jettools.com